



<http://dx.doi.org/10.11646/zootaxa.3670.2.1>

<http://zoobank.org/urn:lsid:zoobank.org:pub:1480445C-0FC7-462B-919F-D35C645A2B90>

Casey's conundrum, a review of the genus *Semanotus* Mulsant (Coleoptera: Cerambycidae: Cerambycinae: Callidiini) in North America

H.E. JAMES HAMMOND & DARYL J. WILLIAMS

Natural Resources Canada: Canadian Forest Service 5320 – 122 Street, Edmonton, Alberta, T6H 3S5 CANADA.

E-mail: James.Hammond@NRCan-RNCan.gc.ca; Daryl.Williams@NRCan-RNCan.gc.ca

Table of contents

Abstract	101
Introduction	102
Materials and methods	102
Results and discussion	107
Morphometric analysis of <i>Semanotus litigiosus</i>	107
Color variation and melanism in <i>Semanotus</i>	111
Phylogenetic analysis of North American <i>Semanotus</i>	111
<i>Semanotus</i> Mulsant, 1839	115
Key to species of North American <i>Semanotus</i>	115
<i>Semanotus amethystinus</i> (LeConte, 1853)	116
<i>Semanotus juniperi</i> (Fisher, 1915)	118
<i>Semanotus litigiosus</i> (Casey, 1891)	118
<i>Semanotus terminatus</i> (Casey, 1912), new status	119
<i>Semanotus ligneus</i> (Fabricius, 1787)	121
<i>Semanotus conformis</i> (Casey, 1912), new status	121
<i>Semanotus amplus</i> (Casey, 1912), new status	122
<i>Semanotus amplus amplus</i> (Casey, 1912), new status	124
<i>Semanotus amplus basalis</i> (Casey, 1924), new status	126
<i>Semanotus amplus sequoiae</i> (Van Dyke, 1923), new status	128
<i>Semanotus australis</i> Giesbert, 1993	130
<i>Semanotus japonicus</i> (Lacordaire, 1869)	134
Acknowledgements	135
Literature cited	135

Abstract

The North American species of *Semanotus* Mulsant, 1839 are reviewed. *Semanotus ligneus* (Fabricius, 1787), *Semanotus amplus amplus* (Casey, 1912) **new status**, *S. amplus basalis* (Casey, 1924) **new status**, *Semanotus amplus sequoiae* Van Dyke, 1923 **new status**, *Semanotus conformis* Casey, 1924 **new status**, *Semanotus terminatus* Casey, 1912 **new status**, *Semanotus amethystinus* (LeConte, 1853), *Semanotus juniperi* (Fisher, 1915), and *Semanotus litigiosus* (Casey, 1891) are recognized as valid. A key to the North American fauna, as well as to *Semanotus japonicus* Lacordaire, 1869 and *Semanotus australis* Giesbert, 1993 is included. A morphometric study was conducted using 37 measured characters from adults of *S. litigiosus*. Data were examined using stepwise discriminant analysis to determine which characters aid in the diagnosis of taxa, and their amounts of resolving power using canonical variates analysis. Morphometrics revealed significant sexual dimorphism among taxa and suggested that three taxa were present, however, only two taxa could be reasonably separated using observable characters. Phylogenetic analysis using a hypothetical ancestor as out-group returned a single most parsimonious tree for North American *Semanotus*.

Key words: Insecta, taxonomy, morphometrics, phylogenetics, wood borer

Introduction

The tribe Callidiini (Cerambycidae: Cerambycinae) in North America is a diverse group represented by 11 genera: *Callidiellum* Linsley, *Callidium* Mulsant, *Elatotrypes* Fisher, *Hylotrypes* Audinet-Serville, *Meriellum* Linsley, *Phymatodes* Mulsant, *Physocnemum* Haldeman, *Pronocera* Motschulsky, *Ropalopus* Mulsant, *Semanotus* Mulsant, and *Xylocrius* LeConte (Linsley 1964). The tribe contains several genera, namely *Callidium*, *Phymatodes* and *Semanotus*, that contain species that are notoriously difficult to identify based on external morphology, and often require host information to place specimens to species. Specimens of *Semanotus* can be recognized from other genera of Callidiini by the densely pubescent eye invagination; pronotum that is apically expanded, basally constricted and as having coarse punctures and various dorsal calluses; relatively weakly clavate femora; males with an aedeagus that is distinctly divided into an apically rounded dorsal lobe and a acutely pointed ventral lobe, and bilobed tegmen. The larvae of *Semanotus* are strictly woodboring (Craighead 1923, Linsley 1964) and can be classified into two broad categories: species that feed and oviposit on Cupressaceae (junipers, cedars, incense-cedar) and Taxodiaceae (redwoods and sequoias), and species that feed and oviposit on Pinaceae (spruce, pine, fir and Douglas-fir) (Linsley and Chemsak 1997).

The genus *Semanotus* has been present in North America since the late Eocene, as fossil remains of *Semanotus puncticollis* Wickham have been recovered from the Florissant Fossil beds in Colorado (Linsley 1942). The last revision of the North American *Semanotus* was by Linsley (1964), where four species were recognized: *S. amethystinus* (LeConte) from the Pacific coast, *S. juniperi* (Fisher) from the mountains of Arizona, *S. litigiosus* (Casey) which is transcontinental, and *S. ligneus* (Fabricius) which was further subdivided into five subspecies (*S. l. ligneus*, *S. l. amplus*, *S. l. sequoiae*, *S. l. basalis*, and *S. l. conformis*). The subspecific designations within *S. ligneus* were based primarily on geographic distribution and host.

As part of a larger field guide to the Cerambycidae of Canada and Alaska (Bousquet *et al.* in preparation), we evaluated the taxonomic status of the North American species of *Semanotus*. We examined the morphology of all currently recognized North American *Semanotus* taxa, and observable diagnostic characters were used in the identification key and diagnosis of species and subspecies. In order to resolve the variability of the *S. litigiosus* group we conducted a morphometric analysis to evaluate *S. litigiosus* and its current synonyms (*S. terminata* Casey and *S. canadensis* Casey). The type specimen of *S. litigiosus* is from southern California, whereas both *S. terminata* and *S. canadensis* were described from eastern North America, so we tested the possibility that these names represented valid taxa. The other *Semanotus* species could be identified using observed characters and did not require morphometric analyses. We also included *S. japonicus* Lacordaire known from Asia, and *S. australis* Giesbert known from Mexico and Central America, in the key as both have been intercepted in North America (Monné and Giesbert 1995, S. Lingafelter, pers. comm.).

Materials and methods

Specimens. A total of 3707 specimens were borrowed and examined from the following institutions or private collections [contact person in brackets]:

AFCF	Atlantic Forestry Centre, Natural Resources Canada: Canadian Forest Service, Fredericton, New Brunswick, Canada.
AMNH	American Museum of Natural History, New York, New York, USA. [Lee Herman]
BYU	Monte L. Bean Life Science Museum, Brigham Young University, Provo, Utah, USA. [Shawn Clarke]
CACA	Collection d'Armond Caron. [now housed at ORUM]
CCCH	Collection de Claude Chantal, Varennes, Quebec, Canada.
CINM	Collection de l'Insectarium de Montréal, Montréal, Quebec, Canada.
CMN	Canadian Museum of Nature, Ottawa, Ontario, Canada. [François Génier]
CMNH	Carnegie Museum of Natural History, Pittsburgh, Pennsylvania, USA. [Robert Davidson]
CNC	Canadian National Collection of Insects, Agriculture and Agri-Food Canada, Ottawa, Ontario, Canada. [Patrice Bouchard, Serge Laplante]
CPTO	Collection de Pierre de Tonnancour, Terrasse-Vaudreuil, Quebec, Canada.

CRJU	Collection de Robert Juan, Lévis, Quebec, Canada.
CRVI	Collection de Robert Vigneault, Oka, Quebec, Canada.
CSUC	C.P. Gillette Museum of Arthropod Diversity, Colorado State University, Department of Bioagricultural Sciences and Pest Management, Fort Collins, Colorado, USA. [Boris Kondratieff]
CUIC	Cornell University Insect Collection, Cornell University, Department of Entomology, Ithaca, New York, USA. [Jason Dombroskie]
EMEC	Essig Museum Entomology Collection, University of California, Department of Entomological Sciences, Berkeley, California, USA. [Peter Oboyski]
FMNH	Field Museum of Natural History, Chicago, Illinois, USA. [Margaret Thayer, James Boone]
FSCA	Florida State Collection of Arthropods, Division of Plant Industry, Florida Department of Agriculture and Consumer Services, Gainesville, Florida, USA. [Michael Thomas, Paul Skelley]
GLFC	Great Lakes Forestry Research Collection, Natural Resources Canada: Canadian Forest Service, Sault Ste. Marie, Ontario, Canada. [Kathryn Nystrom, Isabelle Ochoa]
JBWM	J.B. Wallis Entomological Museum, University of Manitoba, Department of Entomology, Winnipeg, Manitoba, Canada. [Barbara Sharanowski]
MCZC	Museum of Comparative Zoology, Department of Entomology, Harvard University, Cambridge, Massachusetts, USA. [Philip Perkins]
MNMH	Muséum National d'Histoire Naturelle, Paris, France. [Azadeh Taghavian]
MRNF	Ministère des Ressources naturelles et de la Faune, Direction de la protection des forêts, Service de la gestion des ravageurs forestiers, Québec, Québec, Canada. [Céline Piché, Louis Morneau]
MSUC	Albert J. Cook Arthropod Research Collection, Michigan State University, Department of Entomology, East Lansing, Michigan, USA. [Gary Parsons]
NFRC	Northern Forestry Research Collection, Natural Resources Canada: Canadian Forest Service, Edmonton, Alberta, Canada. [Greg Pohl]
ORUM	Collection entomologique Ouellet-Robert, Université de Montréal, Département de sciences biologiques, Montréal, Québec, Canada. [Louise Cloutier]
OSAC	Oregon State Arthropod Collection, Oregon State University, Corvallis, Oregon, USA. [Christopher Marshall]
PFRC	Pacific Forest Research Collection, Natural Resources Canada: Canadian Forest Service, Victoria, British Columbia, Canada. [Lee Humble]
RAAC	Robert A. Androw Personal Collection, Gibsonia, Pennsylvania, USA.
RBCM	Royal British Columbia Museum, Victoria, British Columbia, Canada [Claudia Copley]
TAMU	Texas A&M Insect Collection, Texas A&M University, Department of Entomology, College Station, Texas, USA. [Edward Riley]
UAM	University of Alaska, Fairbanks, Alaska, USA. [Derek Sikes]
UASM	E.H. Strickland Entomological Museum, University of Alberta, Department of Biological Sciences, Edmonton, Alberta, Canada. [Felix Sperling, Danny Shpeley]
UBCZ	George J. Spencer Entomological Museum, University of British Columbia, Department of Zoology, Vancouver, British Columbia, Canada. [Karen Needham]
UMMZ	Museum of Zoology-Insect Division, University of Michigan, Ann Arbor, Michigan, USA. [Mark O'Brien]
UNHC	University of New Hampshire Insect Collection, University of New Hampshire, Department of Biological Sciences, Durham, New Hampshire, USA. [Donald Chandler]
UNMC	Museum of Southwestern Biology, Division of Arthropods, University of New Mexico, Albuquerque, New Mexico, USA. [David Lightfoot]
USNM	Smithsonian Institution, National Museum of Natural History, Department of Entomology, Washington, DC, USA. [Steven Lingafelter, Elisabeth Roberts]
WFBM	W.F. Barr Entomological Museum, University of Idaho, Department of Plant, Soil, and Entomological Sciences, Moscow, Idaho, USA. [Frank Merickel]
WVDA	West Virginia Department of Agriculture Reference Collection, West Virginia Department of Agriculture, Plant Industry Division, Charleston, West Virginia, USA. [Laura Miller]
ZMUC	Zoological Museum, University of Copenhagen, Copenhagen, Denmark. [Alexey Solodovnikov]

Measurements, illustrations and photographs. All observations and measurements were made using a Leica MZ8 dissecting microscope with 16X ocular lens with micrometer and 1.0X objective lens. Habitus and structural photographs were taken with a Leica M80 dissecting microscope with a Leica EC3 camera attached, and structures subsequently rendered into line drawings using OpenOffice Draw v3 (Apache Software Foundation). Habitus photographs were montaged using CombineZP (Hadley 2010). Specimens were gold coated using a Polaron E5000C (PS3) sputter coater, and scanning electron micrographs were obtained using an Hitachi S-510 scanning electron microscope with Quartz PCI image capture software.

Morphometric characters and analysis. Data for morphometric analyses of the *S. litigiousus* group were obtained by measuring 37 morphological characters (Table 1, Fig. 1). All measurements were conducted using morphological landmarks which ensured that specimen orientation was as uniform as possible and measurements consistent. Ten specimens of each sex were measured across the geographic range and size distribution for each species. The mean and range for each population and sex are listed in Table 2.

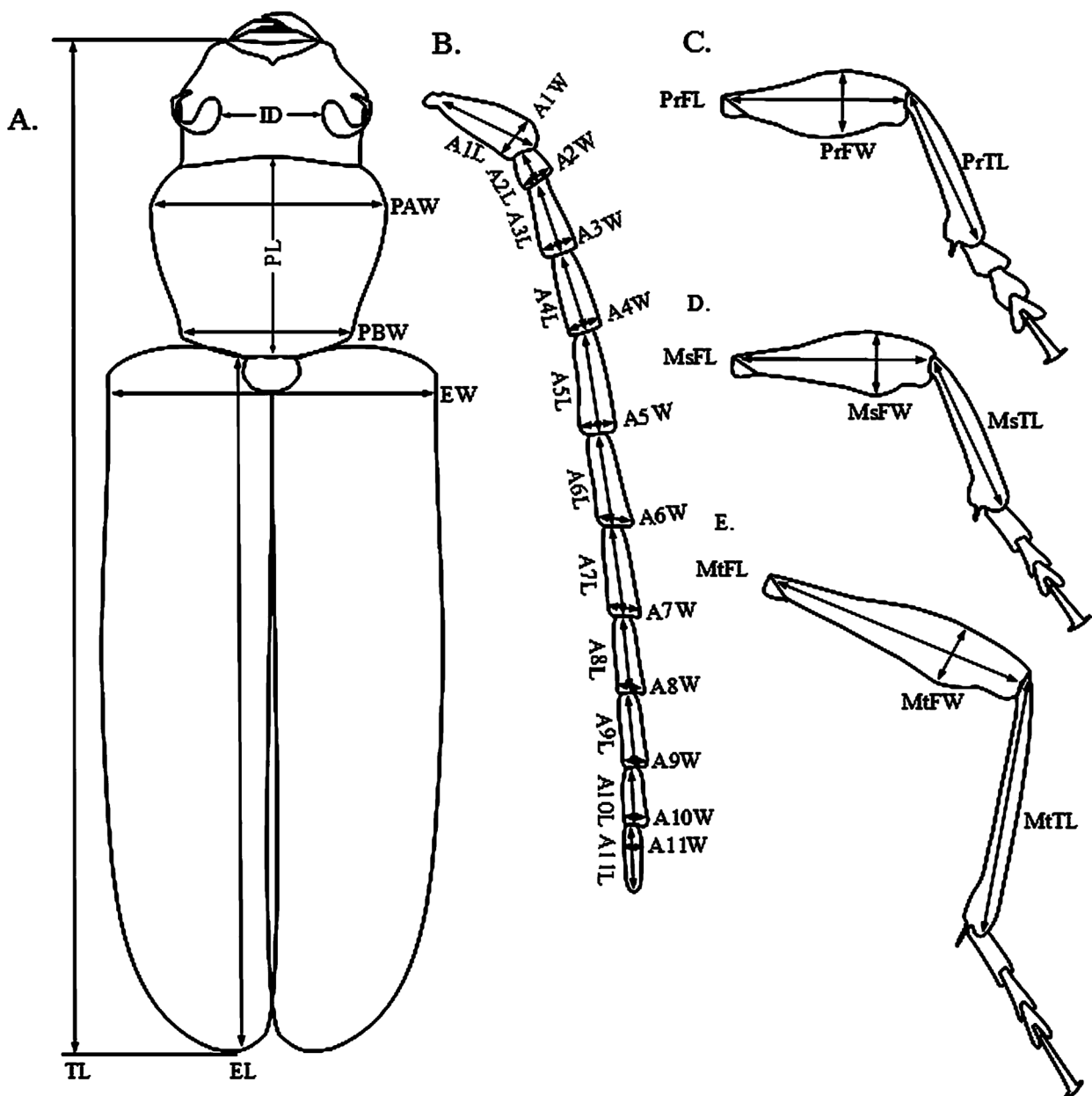

FIGURE 1. Schematic diagram of measurement points on adult *Semanotus litigiousus* group specimens (acronyms as in Table 1). A. Dorsal view of head, pronotum and elytra, B. Antennomeres, C. Fore leg, D. Middle leg, E. Hind leg.

TABLE 1. Morphometric characters measured on adult *Semanotus litigosus* (see Fig. 1).

Num.	Structure	Code	Character
1	Head	ID	Dorsal interocular distance: shortest distance between upper eyelobes, between medial margins
2	Pronotum	PL	Pronotum length: greatest length of pronotum along midline
3	Pronotum	PAW	Pronotal apical width: greatest width of pronotum in apical half
4	Pronotum	PBW	Pronotal basal width: greatest width of pronotum across base
5	Elytra	EL	Elytra length: greatest length of elytra from base of scutellum to apical edge
6	Elytra	EW	Elytral width: greatest width of both elytra between humeri across apex of scutellum
7	Antennae	A1L	Length of Antennomere 1: length of antennomere 1 from insertion suture to apical margin along center axis
8	Antennae	A1W	Width of Antennomere 1: greatest width of antennomere 1 near apex
9	Antennae	A2L	Length of Antennomere 2: length of antennomere 2 from insertion suture to apical margin along center axis
10	Antennae	A2W	Width of Antennomere 2: greatest width of antennomere 2 near apex
11	Antennae	A3L	Length of Antennomere 3: length of antennomere 3 from insertion suture to apical margin along center axis
12	Antennae	A3W	Width of Antennomere 3: greatest width of antennomere 3 near apex
13	Antennae	A4L	Length of Antennomere 4: length of antennomere 4 from insertion suture to apical margin along center axis
14	Antennae	A4W	Width of Antennomere 4: greatest width of antennomere 4 near apex
15	Antennae	A5L	Length of Antennomere 5: length of antennomere 5 from insertion suture to apical margin along center axis
16	Antennae	A5W	Width of Antennomere 5: greatest width of antennomere 5 near apex
17	Antennae	A6L	Length of Antennomere 6: length of antennomere 6 from insertion suture to apical margin along center axis
18	Antennae	A6W	Width of Antennomere 6: greatest width of antennomere 6 near apex
19	Antennae	A7L	Length of Antennomere 7: length of antennomere 7 from insertion suture to apical margin along center axis
20	Antennae	A7W	Width of Antennomere 7: greatest width of antennomere 7 near apex
21	Antennae	A8L	Length of Antennomere 8: length of antennomere 8 from insertion suture to apical margin along center axis
22	Antennae	A8W	Width of Antennomere 8: greatest width of antennomere 8 near apex.
23	Antennae	A9L	Length of Antennomere 9: length of antennomere 9 from insertion suture to apical margin along center axis
24	Antennae	A9W	Width of Antennomere 9: greatest width of antennomere 9 near apex.
25	Antennae	A10L	Length of Antennomere 10: length of antennomere 10 from insertion suture to apical margin along center axis
26	Antennae	A10W	Width of Antennomere 10: greatest width of antennomere 10 near apex.
27	Antennae	A11L	Length of Antennomere 11: length of antennomere 11 from insertion suture to apical margin along center axis
28	Antennae	A11W	Width of Antennomere 11: greatest width of antennomere 11 near apex
29	Fore leg	PrFL	Profemur length: greatest length of profemur from coxal insertion to apex of femur
30	Fore leg	PrFW	Profemur club width: greatest width of profemoral club
31	Fore leg	PrTL	Protibial length: greatest length of protibia along central axis
32	Middle leg	MsFL	Mesofemur length: greatest length of mesofemur from coxal insertion to apex of femur
33	Middle leg	MsFW	Mesofemur club width: greatest width of mesofemoral club

.....continued on the next page

TABLE 1. (Continued)

Num.	Structure	Code	Character
34	Middle leg	MsTL	Mesotibial length: greatest length of mesotibia along central axis
35	Hind leg	MtFL	Metafemur length: greatest length of metafemur from coxal insertion to apex of femur
36	Hind leg	MtFW	Metafemur club width: greatest width of metafemoral club
37	Hind leg	MtTL	Metatibial length: greatest length of metatibia along central axis
38	Total Length	TL	Total Length: greatest length of entire beetle measured from base of mandibles to elytra apex.

Statistical analyses. Ocular measurements were converted to lengths in millimetres. Two types of data were then examined: 1. Normalized measurements: measurements scaled to specimen size to account for size variation among specimens. Total body length was used to normalize the data. 2. Morphometric ratios: proportions of body structures that aid in identification.

Analyses were performed using SAS version 9.2 for Windows (SAS Institute, Inc.). Measurements were analyzed using stepwise discriminant function analysis (STEPDISC) to determine if any of the original measured characters or any of the morphometric ratios were informative. Characters identified in STEPDISC analysis were then used in canonical discriminant analysis (CANDISC) to give a visual estimation of the variation in the data and identify important measured characters.

Phylogenetic analysis. Both continuous and discrete morphological characters were selected for phylogenetic analysis, with continuous characters coded as discrete states (Tables 3 and 4), using the mean and ranges of each character to assign a code. However, this does not preclude overlap in variation among character states. The genera of Callidiini exhibit a wide range of morphological variation and a high incidence of autapomorphic character states, which renders the selection of a single out-group for phylogenetic analysis problematic. Tavakilian (2013) recognizes 31 Callidiini genera worldwide, for which the phylogeny has not been studied and within which there is no indication of which genera may be the most closely related to *Semanotus*. In order to compensate for these difficulties, several genera and species within the Callidiini were examined to reconstruct a hypothetical out-group, including: *Hylotrupes bajulus* (Linnaeus), *Callidium violaceum* (Linnaeus), *Callidiellum rufipenne* (Motschulsky) and *C. cupressi* Van Dyke, *Ropalopus sanguinicollis* (Horn), *Phymatodes alni* (L.) and *P. nitidum* (LeConte). These genera resemble *Semanotus* morphologically and specimens were readily available for study. The state for any character that was shared among the most out-group genera was considered to be the ancestral state for *Semanotus*.

Phylogenetic reconstruction was done with PAUP 4.0 (Swofford 1998) using an out-group rooted, unweighted, exhaustive analysis with maximum parsimony, and the shortest tree presented. Character changes along the phylogeny were examined using Mesquite v2.75 (Maddison and Maddison 2011).

Morphology and terminology in *Semanotus*. Mandibles. The morphology of the mandibles differs greatly among various species of *Semanotus*. The outer mandibular angle ranges from obtuse (>90°) to almost 90°. In some species there is a well defined external flange on the base of the mandible adjacent to the posterior mandibular articulation (appearing ventral as *Semanotus* species are prognathous) which results in a somewhat sinuate outer angle. The medial surface of the mandible is ornamented with a variously developed apical tooth, and some species also possess a basal-medial tooth. **Labrum.** The apical angles of the labrum range from almost square to mostly rounded. The shape of the labrum may be narrowly rectangular, broadly rectangular, or trapezoidal. **Eyes.** As in most Callidiini, the eyes are emarginate and divided into a smaller dorsal lobe and larger ventral lobe. The invagination between the two eyelobes ranges from sparsely to very densely pubescent. **Antennae.** The antennomeres in most *Semanotus* are long with the apical portion serrate, however, there is a high degree of intraspecific variation in this character. Antennae are highly sexually dimorphic with males having much longer and broader antennomeres for their respective body size. Antennae length is highly variable, especially in females. The amount and type of pubescence on the basal antennomeres also varies by species. **Pronotum.** The shape of the pronotum is of two general types: goblet shaped, with the widest part of the pronotum near- or slightly behind the center; and trapezoidal, with the widest part of the pronotum in the apical half. Pronotum shape is sexually dimorphic in that females have a distinctly transverse pronotum, and in males the pronotum tends to be longer. All *Semanotus* species have some form of dorsal callus sculpture on the pronotal disk, which varies from a lyre-shaped pair to having 3–5 more or less distinct oval calluses, which may be small or expanded. **Pubescence.** The color and

type of elytral pubescence is a very useful character in separating species groups. There are two main types of pubescence: long, thin, erect flying hairs found along-side the elytral suture; and the semi-erect to decumbent, coarser setae on the surface of the disk and humeri. The color of the pubescence ranges from pale (light- to dark-yellow) to dark (brown-black), and there may be white pubescence along the humeri in some species. The density and type of pubescence on the ventral surface of the thorax and abdomen also varies among species. **Wing Venation.** Wing vein terminology follows Kukalova-Peck and Lawrence (2004). The hindwings of *Semanotus* range from mostly clear to darkly infusate; wing veins may be bicolored with dark stripes and areas of dark pigmentation associated with veins or cells in some species. Wing veins r3, RP, and RA4 vary in size and development. **Legs.** The femora of most *Semanotus* are described as slightly clavate. However, the profemora are sexually dimorphic, and in males of some western species they are enlarged to nearly clavate-globose. There are two types of pubescence on the tibia: decumbent to semi-erect setae that are generally dense and surround the tibia; and a row of erect flying hairs that form a row on the lateral edge of the tibia which may be present or absent depending on species group.

Male genitalia. Males can be distinguished from females by the shape of abdominal segment V. Males have tergite V large and shield-like with the apical margin either flat or deflexed slightly ventrad, and sternite V slightly shorter, so that the genitalia exit the segment ventrally. In females tergite and sternite V are subequal in length forming a cylinder, so that the internal genitalia exits the segment posteriorly. Terminology for genitalia is taken from Villiers (1978), Mermudes and Napp (2004) and Hammond and Williams (2011).

The male genitalia of *Semanotus* spp. are arranged as in Fig. 8A. Tergite VIII is broad laterally and slightly lobed medially creating a small pocket for the apex of the median lobe. Sternite VIII is similar to other genera in the Callidiini in that it has been reduced to two lateral lobes connected by a median apophysis. Sternite VII is a lightly sclerotized transverse band which overlaps the base of Sternite VIII and part of the spiculum ventrale. The spiculum ventrale is a long, forked structure. The basal apophysis of the spiculum ventrale in lateral view ranges from sinuate to evenly convex. The tegmen is bilobed apically, and basally is formed by the convergence of two lateral apophyses that join to encircle the median lobe. In some species these lateral apophyses fuse to form a single connection basally, in others, the apophyses remain separate, resulting in the basal margin appearing bilobed to emarginate. The apex of the median lobe of the aedeagus is divided into an apically broadly rounded dorsal lobe, and a broadly round to narrowly rounded-apically pointed ventral lobe.

Results and discussion

Morphometric analysis of *Semanotus litigiosus*

Canonical discriminant functions generated two canonical variates which explained 100% of the variation in both sexes (Table 5). Female specimens separated better than males on the first axis, especially the clear grouping of *S. litigiosus* on the right hand side of the plot (Fig. 2). This coincides with other observable characters, such as the shape of the tibial apex and form of the apical tibial setal brush that helped diagnose female *S. litigiosus* from the other forms. Male specimens were harder to distinguish with observable characters, but could be discriminated by measurements such as length to width ratios of the elytra and apical antennomeres. The plot of the canonical discriminant functions (Fig. 2) and the class means for the canonical variables (Table 6) suggests that three distinct forms exist based on measurements.

The initial survey of diagnostic characters from *S. litigiosus* revealed significant morphological variation between the sexes (Table 2), and showed that some of the characters that Casey used indeed seem to separate eastern and western forms (Table 2). Females of each of the forms had wider pronota and longer and wider elytra (Table 2); whereas the antennomeres and the femur and tibia of the males of all forms were longer and wider (Table 2). Further confirmation of sexual dimorphism is given by the stepwise discriminant function analysis which identified five proportional measurements for females and six proportional measurements from males that separated *Semanotus litigiosus* into three groups, none of these characters were shared between sexes (Table 5, Fig. 2).

TABLE 2. Mean \pm SE of morphometric characters of adults of selected *Semanotus* species. Measurements are in millimetres and values in parentheses ranges.

Character	<i>S. litigiousus</i>		<i>S. terminatus</i> (East)		<i>S. terminatus</i> (West)	
	Female (n=10)	Male (n=10)	Female (n=10)	Male (n=10)	Female (n=10)	Male (n=10)
ID	1.10 \pm 0.04 (0.88–1.27)	1.04 \pm 0.04 (0.81–1.23)	0.85 \pm 0.04 (0.65–1.00)	0.81 \pm 0.03 (0.69–0.96)	0.97 \pm 0.03 (0.81–1.15)	0.93 \pm 0.04 (0.73–1.12)
PL	2.18 \pm 0.09 (1.85–2.65)	2.23 \pm 0.06 (1.73–2.50)	1.62 \pm 0.06 (1.31–1.88)	1.60 \pm 0.04 (1.35–1.85)	1.84 \pm 0.07 (1.54–2.27)	1.90 \pm 0.10 (1.35–2.27)
PAW	3.06 \pm 0.14 (2.50–3.81)	2.82 \pm 0.09 (2.23–3.31)	2.21 \pm 0.07 (1.88–2.58)	2.06 \pm 0.05 (1.69–2.35)	2.55 \pm 0.09 (2.15–2.96)	2.41 \pm 0.13 (1.85–3.08)
PBW	2.26 \pm 0.11 (1.88–2.73)	2.08 \pm 0.07 (1.65–2.50)	1.68 \pm 0.06 (1.42–2.00)	1.53 \pm 0.04 (1.31–1.77)	1.95 \pm 0.07 (1.62–2.27)	1.79 \pm 0.11 (1.27–2.42)
EL	7.99 \pm 0.35 (6.80–9.55)	7.55 \pm 0.18 (6.19–8.32)	6.58 \pm 0.19 (5.57–7.56)	5.85 \pm 0.16 (5.27–6.95)	7.47 \pm 0.31 (6.03–8.63)	6.75 \pm 0.30 (5.35–8.17)
EW	3.87 \pm 0.18 (3.12–4.65)	3.65 \pm 0.11 (2.77–4.08)	2.82 \pm 0.09 (2.38–3.19)	2.57 \pm 0.07 (2.27–3.00)	3.29 \pm 0.13 (2.73–3.85)	3.12 \pm 0.17 (2.31–3.88)
A1L	0.98 \pm 0.03 (0.85–1.12)	1.20 \pm 0.04 (0.97–1.34)	0.76 \pm 0.03 (0.62–0.89)	0.87 \pm 0.02 (0.75–1.02)	0.89 \pm 0.04 (0.69–1.05)	1.03 \pm 0.04 (0.83–1.18)
A1W	0.36 \pm 0.01 (0.31–0.42)	0.48 \pm 0.02 (0.37–0.57)	0.29 \pm 0.01 (0.26–0.34)	0.37 \pm 0.01 (0.31–0.42)	0.31 \pm 0.01 (0.23–0.38)	0.41 \pm 0.02 (0.31–0.48)
A2L	0.27 \pm 0.01 (0.46–0.71)	0.40 \pm 0.01 (0.34–0.49)	0.21 \pm 0.01 (0.18–0.25)	0.27 \pm 0.01 (0.23–0.34)	0.25 \pm 0.01 (0.22–0.31)	0.32 \pm 0.02 (0.23–0.43)
A2W	0.25 \pm 0.01 (0.20–0.29)	0.35 \pm 0.01 (0.28–0.42)	0.21 \pm 0.01 (0.18–0.25)	0.28 \pm 0.01 (0.23–0.34)	0.23 \pm 0.01 (0.18–0.28)	0.31 \pm 0.01 (0.25–0.35)
A3L	0.69 \pm 0.02 (0.54–0.82)	0.98 \pm 0.03 (0.82–1.17)	0.51 \pm 0.02 (0.43–0.57)	0.69 \pm 0.02 (0.57–0.83)	0.60 \pm 0.03 (0.49–0.72)	0.83 \pm 0.04 (0.63–1.08)
A3W	0.30 \pm 0.01 (0.25–0.35)	0.41 \pm 0.02 (0.31–0.49)	0.24 \pm 0.01 (0.22–0.26)	0.32 \pm 0.01 (0.28–0.37)	0.27 \pm 0.01 (0.22–0.32)	0.36 \pm 0.02 (0.28–0.42)
A4L	0.78 \pm 0.03 (0.66–0.92)	1.11 \pm 0.04 (0.91–1.32)	0.55 \pm 0.02 (0.43–0.62)	0.76 \pm 0.03 (0.68–0.91)	0.66 \pm 0.03 (0.51–0.85)	0.94 \pm 0.05 (0.66–1.18)
A4W	0.31 \pm 0.01 (0.26–0.37)	0.41 \pm 0.02 (0.31–0.49)	0.24 \pm 0.01 (0.22–0.26)	0.31 \pm 0.01 (0.26–0.37)	0.27 \pm 0.01 (0.22–0.31)	0.34 \pm 0.01 (0.28–0.40)
A5L	0.96 \pm 0.04 (0.8–1.15)	1.32 \pm 0.04 (1.08–1.60)	0.67 \pm 0.02 (0.54–0.74)	0.91 \pm 0.03 (0.8–1.05)	0.82 \pm 0.04 (0.62–1.02)	1.14 \pm 0.06 (0.78–1.38)
A5W	0.32 \pm 0.01 (0.28–0.40)	0.40 \pm 0.01 (0.31–0.46)	0.25 \pm 0.01 (0.22–0.29)	0.30 \pm 0.01 (0.25–0.35)	0.28 \pm 0.01 (0.23–0.32)	0.35 \pm 0.01 (0.28–0.38)
A6L	0.86 \pm 0.04 (0.71–1.02)	1.23 \pm 0.04 (1.02–1.40)	0.64 \pm 0.01 (0.54–0.68)	0.85 \pm 0.03 (0.75–1.00)	0.75 \pm 0.04 (0.58–0.92)	1.06 \pm 0.05 (0.77–1.23)
A6W	0.31 \pm 0.01 (0.26–0.38)	0.38 \pm 0.01 (0.29–0.43)	0.24 \pm 0.01 (0.22–0.28)	0.29 \pm 0.01 (0.23–0.32)	0.27 \pm 0.01 (0.23–0.31)	0.33 \pm 0.01 (0.26–0.40)
A7L	0.82 \pm 0.03 (0.66–0.98)	1.20 \pm 0.03 (0.95–1.38)	0.60 \pm 0.02 (0.48–0.68)	0.80 \pm 0.03 (0.69–0.97)	0.71 \pm 0.03 (0.54–0.88)	1.04 \pm 0.06 (0.72–1.26)
A7W	0.29 \pm 0.01	0.35 \pm 0.01	0.23 \pm 0.01	0.26 \pm 0.01	0.26 \pm 0.01	0.30 \pm 0.01

.....continued on the next page

TABLE 2. (Continued)

Character	<i>S. litigiousus</i>		<i>S. terminatus</i> (East)		<i>S. terminatus</i> (West)	
	Female (n=10)	Male (n=10)	Female (n=10)	Male (n=10)	Female (n=10)	Male (n=10)
A8L	(0.23–0.35) 0.70 ± 0.03	(0.28–0.42) 1.07 ± 0.03	(0.20–0.26) 0.52 ± 0.02	(0.22–0.31) 0.70 ± 0.03	(0.22–0.29) 0.61 ± 0.04	(0.23–0.37) 0.90 ± 0.05
A8W	(0.58–0.82) 0.28 ± 0.01	(0.92–1.23) 0.32 ± 0.01	(0.43–0.58) 0.22 ± 0.01	(0.6–0.88) 0.24 ± 0.01	(0.46–0.82) 0.25 ± 0.01	(0.62–1.06) 0.28 ± 0.01
A9L	(0.25–0.32) 0.69 ± 0.03	(0.25–0.37) 1.04 ± 0.02	(0.20–0.25) 0.50 ± 0.02	(0.20–0.28) 0.68 ± 0.02	(0.20–0.28) 0.60 ± 0.04	(0.22–0.34) 0.87 ± 0.05
A9W	(0.58–0.85) 0.27 ± 0.01	(0.86–1.17) 0.28 ± 0.01	(0.42–0.57) 0.20 ± 0.01	(0.58–0.85) 0.21 ± 0.01	(0.45–0.85) 0.24 ± 0.01	(0.60–1.09) 0.25 ± 0.01
A10L	(0.23–0.31) 0.58 ± 0.03	(0.23–0.32) 0.92 ± 0.03	(0.18–0.23) 0.42 ± 0.01	(0.18–0.23) 0.56 ± 0.02	(0.20–0.26) 0.52 ± 0.03	(0.18–0.31) 0.73 ± 0.04
A10W	(0.46–0.71) 0.25 ± 0.01	(0.80–1.09) 0.26 ± 0.01	(0.34–0.48) 0.20 ± 0.01	(0.48–0.69) 0.20 ± 0.01	(0.38–0.69) 0.22 ± 0.01	(0.52–0.91) 0.22 ± 0.02
A11L	(0.22–0.29) 0.67 ± 0.03	(0.22–0.31) 1.10 ± 0.04	(0.18–0.22) 0.51 ± 0.02	(0.18–0.22) 0.72 ± 0.03	(0.18–0.25) 0.62 ± 0.04	(0.17–0.26) 0.85 ± 0.04
A11W	(0.54–0.83) 0.23 ± 0.01	(0.97–1.32) 0.22 ± 0.01	(0.45–0.58) 0.17 ± 0.01	(0.62–0.88) 0.17 ± 0.01	(0.46–0.85) 0.19 ± 0.01	(0.62–1.12) 0.18 ± 0.01
PrFL	(0.18–0.26) 2.16 ± 0.08	(0.18–0.25) 2.47 ± 0.07	(0.15–0.20) 1.66 ± 0.04	(0.15–0.18) 1.83 ± 0.05	(0.15–0.20) 1.85 ± 0.06	(0.15–0.22) 2.12 ± 0.10
PrFW	(1.85–2.58) 0.77 ± 0.03	(2.04–2.73) 0.93 ± 0.03	(1.46–1.85) 0.58 ± 0.01	(1.62–2.12) 0.67 ± 0.02	(1.54–2.12) 0.66 ± 0.02	(1.50–2.54) 0.78 ± 0.03
PrTL	(0.65–0.92) 1.96 ± 0.07	(0.73–1.04) 2.19 ± 0.07	(0.54–0.65) 1.47 ± 0.05	(0.58–0.77) 1.60 ± 0.04	(0.58–0.77) 1.75 ± 0.08	(0.62–0.92) 1.89 ± 0.08
MsFL	(1.62–2.35) 2.65 ± 0.10	(1.77–2.58) 3.22 ± 0.11	(1.19–1.65) 1.92 ± 0.06	(1.38–1.85) 2.31 ± 0.07	(1.38–2.12) 2.30 ± 0.10	(1.42–2.15) 2.71 ± 0.13
MsFW	(2.27–3.12) 0.75 ± 0.03	(2.50–3.69) 0.96 ± 0.03	(1.62–2.19) 0.54 ± 0.02	(1.96–2.69) 0.72 ± 0.02	(1.81–2.69) 0.63 ± 0.02	(1.92–3.15) 0.79 ± 0.03
MsTL	(0.65–0.92) 2.35 ± 0.09	(0.73–1.08) 2.82 ± 0.08	(0.46–0.62) 1.76 ± 0.06	(0.58–0.88) 1.97 ± 0.06	(0.54–0.73) 2.11 ± 0.10	(0.65–0.92) 2.34 ± 0.12
MtFL	(1.96–2.85) 3.37 ± 0.11	(2.27–3.12) 4.06 ± 0.13	(1.46–2.00) 2.58 ± 0.08	(1.69–2.31) 2.92 ± 0.09	(1.69–2.50) 3.00 ± 0.13	(1.73–2.85) 3.45 ± 0.18
MtFW	(2.96–3.96) 0.78 ± 0.03	(3.27–4.46) 0.96 ± 0.04	(2.15–2.92) 0.59 ± 0.02	(2.54–3.42) 0.76 ± 0.02	(2.38–3.54) 0.67 ± 0.02	(2.54–4.08) 0.81 ± 0.03
MtTL	(0.69–0.92) 3.18 ± 0.12	(0.73–1.08) 3.80 ± 0.13	(0.50–0.69) 2.48 ± 0.07	(0.65–0.92) 2.76 ± 0.09	(0.58–0.77) 2.95 ± 0.13	(0.65–0.92) 3.28 ± 0.15
TL	(2.62–3.85) 11.15 ± 0.47	(3.04–4.35) 10.92 ± 0.29	(2.08–2.73) 9.03 ± 0.25	(2.38–3.19) 8.33 ± 0.18	(2.35–3.42) 10.21 ± 0.42	(2.50–3.88) 9.46 ± 0.49
	(9.40–13.09)	(8.81–12.02)	(7.74–10.00)	(7.62–9.40)	(8.45–12.38)	(6.90–11.54)

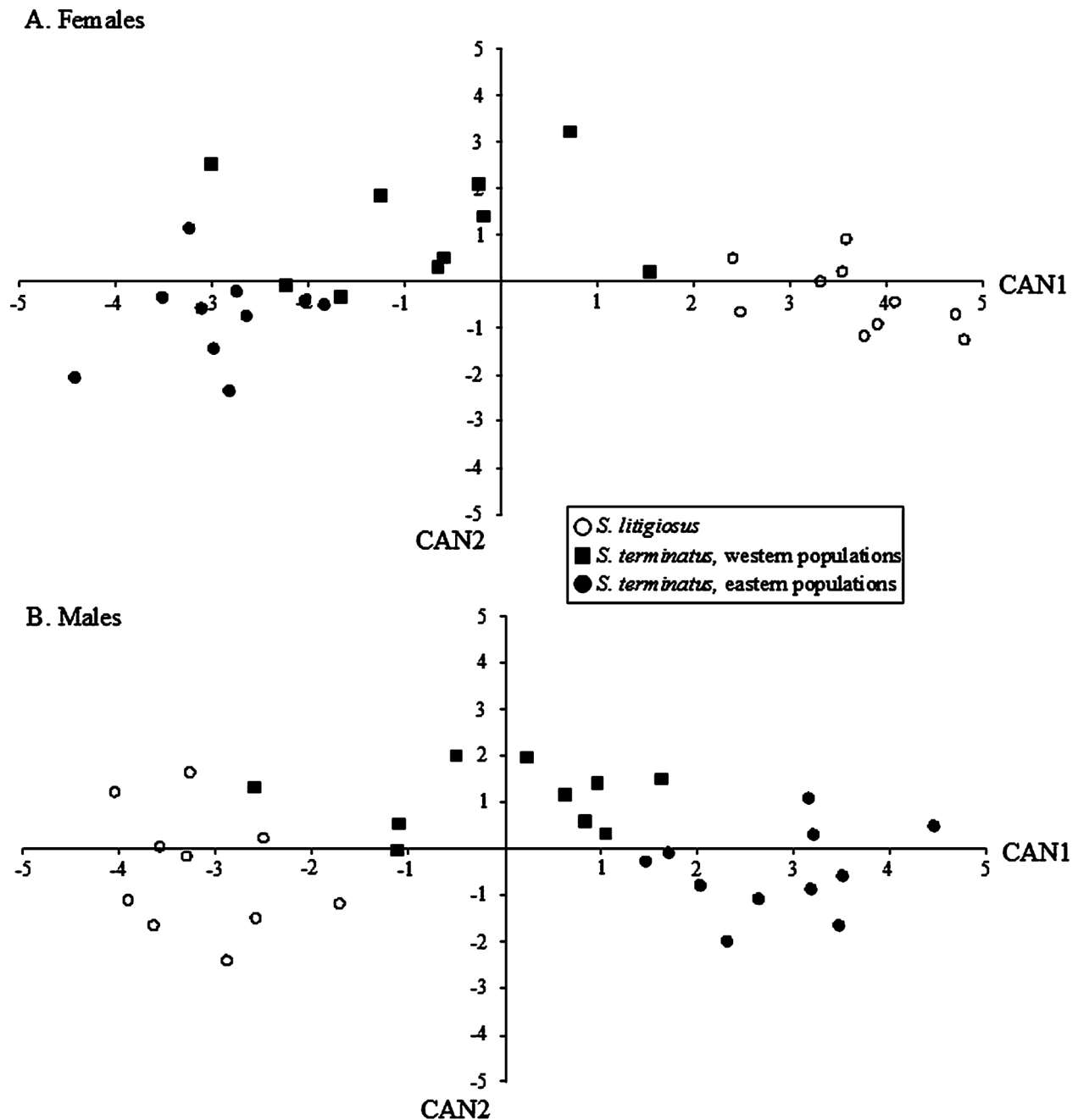

FIGURE 2. Plot of the first two canonical variates for *Semanotus litigiosus* group specimens in North America. Ten female and 10 male specimens from each population were measured for each species.

Casey described three species of *Semanotus* that Linsley (1964) later synonymised: *S. litigiosus* (1891) in the genus *Hylotrupes*, and *S. terminata* (1912) and *S. canadensis* (1924) in the genus *Anocomis*. The type specimen for *S. litigiosus* was collected and described from California. The type specimen for *S. terminata* was a female collected from Maine, and the type specimen for *S. canadensis* was a male collected near Ottawa Ontario, all of which were examined. Interestingly, one of the characters Casey used to distinguish *S. canadensis* from *S. terminata* was the smaller size of *S. canadensis*. We now know small males are common in many Cerambycidae species. Casey also used other characters such as the length and form of the antennae, pronotum and elytra to distinguish the three species.

We consider the eastern form, associated with *Picea mariana* (black spruce) to be a valid species, *S. terminatus*, of which *S. canadensis* is a junior synonym. We also consider the strictly western *S. litigiosus* to be a valid species based on clear diagnostic characters. It is possible given the results of the morphometric analysis that

the western form of *S. terminatus*, associated with *Picea glauca* (white spruce) and *Pseudotsuga menziesii* (Douglas fir) might comprise a third undescribed species. However, as we have been unable to discover any diagnostic characters which do not overlap extensively between the eastern and western forms we have decided to be conservative and retain both populations in *S. terminatus* in this study. It is possible that future analyses such as DNA barcoding might provide better resolution than adult morphology, which is equivocal.

Color variation and melanism in *Semanotus*

Coloration of specimens and the form and type of elytral punctation has long been used as a diagnostic character for North American *Semanotus* species, especially for the ‘*ligneus* group’ of subspecies. In Casey’s reviews of the North American species (1912, 1924), he defined many of his nine new species by the extent and form of the black maculation on the elytra as well as punctation density and surface sculpture. Linsley (1964) took a more conservative approach and synonymised many of Casey’s species, but maintained five subspecies of *S. ligneus*, mostly based on color form, geographic range and host.

We used specimens of *S. australis* of a single series collected from the same host (a single log of *Cupressus lusitanica*) collected by Giesbert (1993) as an index of intraspecific color variation in American *Semanotus* species. The series examined was comprised mainly of individuals with bicolored elytra, but there were also several individuals of a maculate form and a melanic form (Figure 15B). We were unable to find diagnostic morphological differences among the forms.

Other American taxa of *Semanotus* vary in a similar fashion. Each species and subspecies may have melanistic forms that resemble one another. Some individuals of *S. conformis*, for example, may have elytra that are somewhat melanised and resemble some individuals of *S. a. basalis*. Interestingly, the diagnostic character for *S. ligneus*, the possession of light colored elytral setae in areas that are light colored in other specimens, is retained in melanistic *S. ligneus* specimens. Because we have generally found ground color pattern to be variable and of little use in distinguishing species we have not retained many of the subspecific categories used by previous authors, particularly since we could not find reliable morphological characters that were diagnostic for these taxa. The exception to this is our treatment of *S. amplus* and its subspecific taxa. The subspecies of *S. amplus* are retained on the basis of a wide but overlapping range of morphological variation compared to other American *Semanotus* species combined with somewhat diagnostic color patterns (with aberrant individuals difficult to place), but also with an observable pattern of geographic distribution and/or host preference (see below). On the basis of morphology we cannot determine whether the combination of host and somewhat distinctive color pattern indicate separate species or simply host races, so these three taxa are retained as subspecies of *S. amplus* for the present.

Phylogenetic analysis of North American *Semanotus*

Of the 34 characters used in the phylogenetic analysis (Table 3, Table 4), two are ecological (1, 2), twelve are binary (3, 4, 6, 9, 16, 23–25, 28, 29, 31, 34) and twenty-two are multistate (1, 2, 5, 7, 8, 10–15, 17–22, 26, 27, 30, 32, 33). Seventeen of the multistate characters are ordered (7, 8, 10–12, 14, 15, 17–22, 26, 27, 30, 33), and five unordered (1, 2, 5, 13, 32). Characters 1 and 2 deal with hosts. Host preference within the Callidiini falls into three general categories: 1) genera that prefer deciduous hosts (e.g. *Calydon* Thomson, *Leioderes* Redtenbacher, *Physocnemum* Haldeman); 2) genera that prefer coniferous hosts (e.g. *Callidiellum* Linsley, *Elatotrypes* Fisher, *Meriellum* Linsley, *Pronocera* Motschulsky); and 3) genera that are polyphagous (*Turanium* Baeckmann, *Poecilium* Fairemaire, *Phymatodes* Mulsant) (Bense 1995, Linsley and Chemsak 1997, Sama 2002, Rizzuto 2009). We have assigned the ancestral host as ‘unknown’ on this basis, and given the degree of host plasticity in the tribe and among species have decided to leave these characters unordered. For characters 5, 13, and 32 states were sufficiently different from one another and from the hypothetical ancestral state that it was assumed that any state could have been derived from any other state.

Phylogenetic analysis returned a single most parsimonious tree (Fig 3., Number of steps = 97, CI = 0.6392, RI = 0.6635). There are 23 hypothesized homoplasies representing both reversals (14 characters) and independent derivations of apomorphic states (13 characters). The placement of the *S. amethystinus*+*S. juniperi* clade at the

base of *Semanotus* reflects that these taxa are unique among *Semanotus* species in size and habitus. They have very large body size, uniquely shaped pronota, metallic unicolorous elytra, a reduction in pubescence, and almost cylindrical femora. These two species are sufficiently different that they could be removed from *Semanotus* and placed in their own genus, but this would have to be done in the context of a phylogenetic study of the entire Callidiini using ancestral states for all of the genera rather than a single hypothetical ancestor.

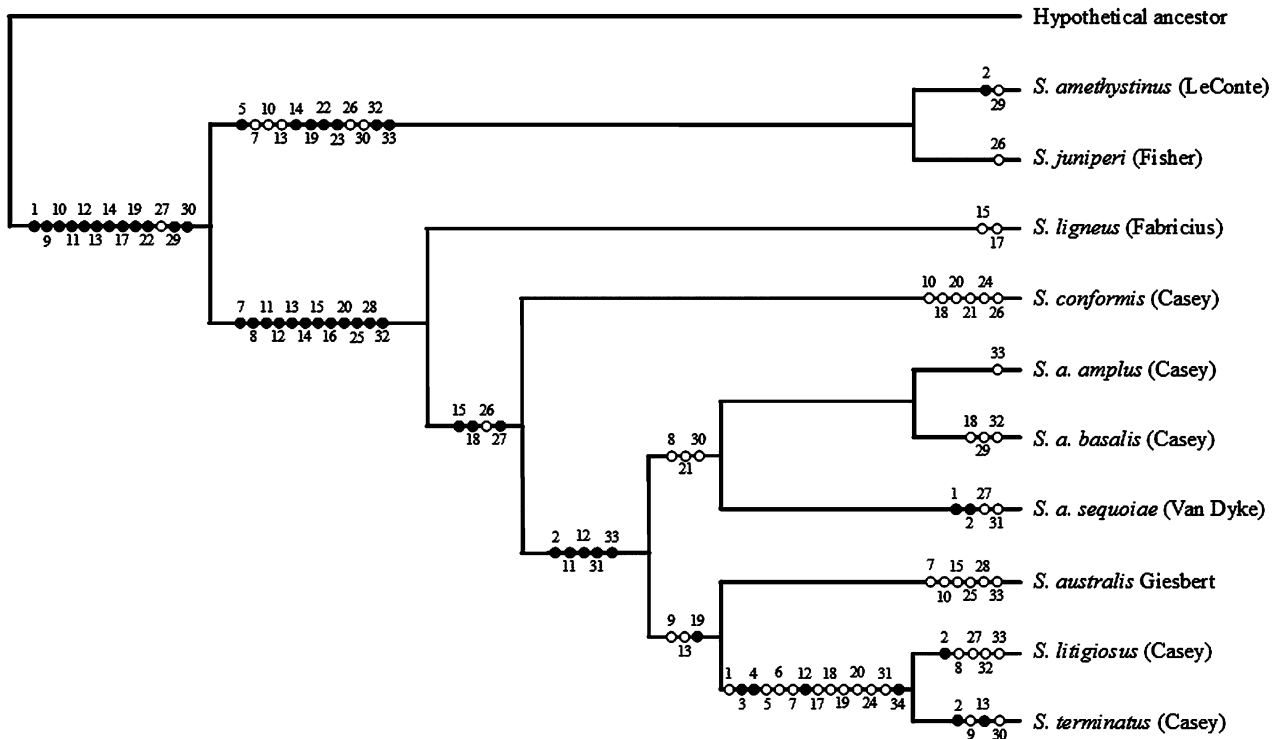

FIGURE 3. Reconstructed phylogeny of North American *Semanotus* spp. using a hypothetical ancestor as the out-group. Circles represent apomorphic character changes along each branch. Open circles represent homoplastic characters.

TABLE 3. Characters and states used in phylogenetic analysis of North American *Semanotus* species.

Num.	Character	States	Type
1	Host–Family	0–Pinaceae, 1–Cupressaceae, 2–Taxodiaceae	Unordered
2	Host–Genus	0– <i>Pinus</i> , 1– <i>Libocedrus</i> , 2– <i>Juniperus</i> , 3– <i>Thuja</i> , 4– <i>Sequoia</i> , 5– <i>Abies</i> , 6– <i>Pseudotsuga</i> , 7– <i>Picea</i> , 8– <i>Cupressus</i>	Unordered
3	Mandible tooth	0–Absent, 1–Present	Ordered
4	Shape of mandibular apex	0–Broadly pointed, 1–Acutely pointed	Ordered
5	Lateral mandibular flange	0–Absent, 1–Present, apex of flange rounded, 2–Present, apex of flange acute	Unordered
6	Outer mandibular angle	0–Acute, approximately 90°, 1–obtuse, >90°	Ordered
7	Labrum shape	0–Narrowly rectangular, 1–Broadly rectangular, 2–Trapezoidal	Ordered
8	Eye invagination pubescence	0–Sparse, 1–Dense, 2–Very dense	Ordered
9	Male antennal length	0–Very long (>elytra apex), 1–Long (>1/2 elytra)	Ordered
10	Female antennal length	0–Long (>1/2 elytra), 1–Short (~1/2 elytra), 2–Very short	Ordered
11	Male pronotum shape	0–Longitudinally oval, 1–Goblet shaped, 2–Trapezoidal round, 3–Trapezoidal angulate, 4–Trapezoidal transverse	Ordered
12	Female pronotum shape	0–Transversely oval, 1–Goblet shaped, 2–Trapezoidal round, 3–Trapezoidal angulate, 4–Trapezoidal transverse	Ordered
13	Size pronotal callosities	0–Absent, 1–Small, 2–Medium, 3–Large	Unordered

.....continued on the next page

TABLE 3. (Continued)

Num.	Character	States	Type
14	Shape pronotal callosities	0—Absent, 1—Present Lyre shaped, 2—Present elongate oval	Ordered
15	Pronotal punctation density	0—Sparse, 1—Dense, 2—Very dense to contiguous	Ordered
16	Elytra color	0—Unicolor, 1—Polymorphic	Ordered
17	Elytral disk pubescence color	0—Unicolor pale, 1—Dark and pale, 2—Unicolor dark	Ordered
18	White elytral humeri pubescence	0—Absent, 1—Restricted to basal 1/4 elytra, 2—Extends to 1/2 elytra length	Ordered
19	Elytra sutural setae	0—Present to apex dense and distinct, 1—Present to apex sparse and somewhat indistinct, 2—Present, <1/2 elytral length, 3—Absent	Ordered
20	Ventral pubescence	0—Sparse, 1—Dense, 2—Very dense	Ordered
21	Leg color	0—Unicolor, 1—femura different from tibiae and tarsi	Ordered
22	Femoral club	0—Distinctly clavate, 1—Moderately clavate, 2—Cylindrical	Ordered
23	Female Meso– Metatibiae flying hairs	0—Present, 1—Absent	Ordered
24	r3 hindwing vein	0—Present, reduced to short spur, 1—Absent	Ordered
25	RP hindwing vein	0—Present, 1—Absent	Ordered
26	RA4 hindwing vein	0—Present, 1—Reduced, 2—Absent	Ordered
27	Aedeagus, Length:Width ratio	0— ≤ 4 , 1—4 to 5, 2— >5	Ordered
28	Apex of aedeagus dorsal lobe	0—Narrowly round, 1—Broadly round	Ordered
29	Apex of aedeagus ventral lobe	0—Narrowly round, 1—Broadly round	Ordered
30	Tegmen lateral apophysis length	0—Short, 1—Medium, 2—Long	Ordered
31	Anterior-ventral confluence of tegmen ring	0—Single join, 1—Distinct, emarginate	Ordered
32	Shape of spiculum ventrale basal apophysis	0—Apex acutely bent, 1—Apex sinuate, 2—Apex evenly curved	Unordered
33	Length of spiculum ventrale basal apophysis	0—1.5X lateral apophysis length, 1—2X lateral apophysis length, 2— $>2X$ lateral apophysis length	Ordered
34	Length of sternum VIII basal apophysis	0—Short, 1—Long	Ordered

TABLE 4. Character data matrix for *Semanotus* and a hypothetical Callidiini ancestor.

Species	1	2	3	4	5	6	7	8	9	10	11	12	13	14	15	16	17
<i>S.amethystinus</i>	1	1	0	0	2	1	1	0	1	2	1	1	3	1	0	0	2
<i>S. juniperi</i>	1	2	0	0	2	1	1	0	1	2	1	1	3	1	0	0	2
<i>S. ligneus</i>	1	(23)	0	0	1	1	2	1	1	1	2	2	2	2	1	1	1
<i>S. conformis</i>	1	2	0	0	1	1	2	1	1	2	2	2	2	2	2	1	2
<i>S. amplus amplus</i>	1	(18)	0	0	1	1	2	2	1	1	3	3	2	2	2	1	2
<i>S. amplus basalis</i>	1	3	0	0	1	1	2	2	1	1	3	3	2	2	2	1	2
<i>S. amplus sequoiae</i>	2	4	0	0	1	1	2	2	1	1	3	3	2	2	2	1	2
<i>S. litigiosus</i>	0	(56)	1	1	0	0	0	2	0	1	3	4	3	2	2	1	1
<i>S. terminatus</i>	0	(67)	1	1	0	0	0	1	1	1	3	4	(12)	2	2	1	1
<i>S. australis</i>	1	8	0	0	1	1	1	1	0	0	3	3	3	2	1	1	2
†Hypothetical Ancestor	?	?	0	0	0	0	0	0	0	0	0	0	0	0	0	0	0

continued.

Species	18	19	20	21	22	23	24	25	26	27	28	29	30	31	32	33	34
<i>S.amethystinus</i>	0	3	0	0	2	1	0	0	1	2	0	0	2	0	1	2	0
<i>S. juniperi</i>	0	3	0	0	2	1	0	0	2	2	0	1	2	0	1	2	0
<i>S. ligneus</i>	0	2	1	0	1	0	0	1	0	2	1	1	1	0	2	0	0
<i>S. conformis</i>	2	2	2	(01)	1	0	1	1	2	1	1	1	1	0	2	0	0
<i>S. amplus amplus</i>	1	2	1	1	1	0	0	1	1	1	1	1	0	(01)	2	1	0
<i>S. amplus basalis</i>	2	2	1	(01)	1	0	0	1	1	1	1	0	0	(01)	0	(01)	0
<i>S. amplus sequoiae</i>	1	2	1	(01)	1	0	0	1	1	2	1	1	0	1	2	(01)	0
<i>S. litigiosus</i>	2	0	2	0	1	0	1	1	1	2	1	1	1	1	0	2	1
<i>S. terminatus</i>	2	0	2	0	1	0	1	1	1	1	1	1	2	1	2	(01)	1
<i>S. australis</i>	1	1	1	0	1	0	0	0	1	1	0	1	1	(01)	2	1	0
†Hypothetical Ancestor	0	0	0	0	0	0	0	0	0	0	0	0	0	0	0	0	0

† Hypothetical ancestor based on mean character states of the following species: *Hylotropes bajulus*, *Callidiellum rufipennis*, *Callidiellum cupressi*, *Callidium violaceum*, *Ropalopus sanguinicollis*, *Phymatodes alni*, *Phymatodes nitidum*.

TABLE 5. Standardized canonical coefficients and cumulative percentage of variation explained per canonical variate for morphometric data of *Semanotus litigiosus*. All characters were rated significant by STEPDISC analysis.

Females		Males			
Character	CAN1	CAN1	Character	CAN1	CAN2
EW/TL	1.8325	0.1357	EL/EW	1.1388	0.2066
MsFW/TL	1.2075	-0.2300	MtFL/TL	-0.8963	0.0087
A5L/A10L	0.6421	0.4552	A9L/A10L	0.8949	-0.4496
A1W/TL	-0.4928	1.0277	ID/TL	0.6384	0.5548
MtFL/TL	-0.0532	-0.4267	A5L/A11L	0.1637	1.4171
Cumulative Variation (%)	95.91	100	A5L/A7L	0.2634	-0.9211
			Cumulative Variation (%)	86.74	100

TABLE 6. Class means on canonical variables based on morphometric data for *Semanotus* species.

Species	Females		Males	
	CAN1	CAN2	CAN1	CAN2
<i>S. litigiosus</i>	3.2789	0.2129	-2.7532	-0.5025
<i>S. terminatus</i> (East)	-2.5321	0.4801	2.3383	-0.6214
<i>S. terminatus</i> (West)	-0.7467	-0.6931	0.1811	1.1861

The large number of apomorphic characters in the second dichotomy of the phylogeny reflects the fact that these two species lack many of the distinguishing and diagnostic features of the remainder of the genus. As expected, the three subspecies of *S. amplus* form a clade. It is interesting that they are not most closely related to *S. ligneus*, the species with which they are commonly confused. The position of *S. australis* in the phylogeny was less expected, as superficially they seem very similar to the *S. amplus* group given their shared color polymorphism. This species shares 23 characters with at least one of the *S. amplus* subspecies, 15 of these derived characters. *S. australis* is somewhat morphologically dissimilar from the other *S. amplus* group taxa in that they have the plesiomorphic character of longer antennae, a more rectangular labrum, a more densely punctate pronotum with very large prominent callosities, and a glabrous impunctate scutellum. However, they do have derived characters that unite both the *S. amplus* group and the *S. litigiosus* group, such as pronotal shape and certain genitalic features. It is noteworthy that the majority of the homoplastic characters involving reversals were seen in the *S. australis*+*S.*

litigiosus+*S. terminatus* clade. This may be related to a trend in the genus towards reduced size, or a reflection of the host reversal to Pinaceae for *S. litigiosus*+*S. terminatus*. This shift, occurring within the clade and excluding *S. australis*, may also explain why *S. australis* is more similar to other *Semanotus* species than to its closest relatives in that it retains a more typical *Semanotus* habitus and many morphological characters subsequently lost in *S. litigiosus*+*S. terminatus*.

Semanotus Mulsant, 1839

Semanotus Mulsant, 1839: 54
Sympiezocera Lucas, 1853: cvi
Xenodorum Marseul, 1856: 48
Hylotrupes LeConte, 1873: 296
Anocomis Casey, 1912: 271
Hemicallidium Casey, 1912: 273
Anacomis Leng, 1920: 275

Diagnosis. Members of this genus can be separated from other genera of the Callidiini by the following combination of characters: body moderately broad, convex to slightly flattened; antennae 11-segmented and varying from reaching about the middle of the elytra to surpassing elytral apex; antennomeres 3–10 apically widened with antennomeres 6–11 moderately flattened in cross section; pronotum usually wider than long, narrowed to pedunculate at base, laterally rounded to angulate, disk with dorsal callosities that are separated into 3 to 5 more or less distinct calli or fused in various configurations; prosternal process wide and expanded behind procoxae; femora slightly clavate; tarsal claws simple; apex of aedeagus divided into a flat plate-like dorsal lobe that is apically rounded and ventral lobe that is pointed to slightly aciculate; tegmen bilobed.

Hosts. *Juniperus* spp. (junipers), *Sequoia* spp. (redwoods), *Libocedrus* sp. (incense-cedar), *Pseudotsuga* sp. (Douglas-fir), *Cupressus* spp. (cypress), *Thuja* spp. (cedar), *Picea* spp. (spruces), *Pinus* spp. (pines), *Abies* spp. (firs).

Flower and Associated Vegetation Records. *Chaemaecyparis* sp. (cedar)

Distribution. Transcontinental in North America, from Alaska south to Texas; southern Mexico southeast through Guatemala and Honduras; in the Palaearctic from Algeria and Morocco, throughout Asia including the middle east, China, Japan, and Nepal, from most of continental Europe and the Scandinavian countries.

Remarks. This diverse genus is superficially similar to many genera within the Callidiini including *Xylocrius*, *Hylotrupes*, *Callidium*, *Ropalopus*, and *Pyrrhidium* in that they share a similar habitus and have a pronotum that is variously sculptured. They differ from these species in that the front coxae are divided by a narrow prosternal process, tarsal claws are simple, the femora only slightly clavate and apical antennomeres dorso-ventrally flattened.

Key to species of North American *Semanotus*

1. Pronotum goblet shaped, rounded laterally, constricted and sinuate near base forming a short, wide pedicel between pronotum and base of elytra (Fig 4A); meso- and metatibia of female without row of long, erect setae along outside lateral edge; elytra unicolorous metallic purple, blue or black; large species [length 12–30 mm] 2
- Pronotum rounded to angulate laterally, often constricted towards base but not forming a distinct pedicel between pronotum and base of elytra (Fig 4B); meso- and metatibia of female usually with distinct row of very long, erect setae along outside lateral edge; smaller species, often with elytra maculate with either spots or bands 3
- 2(1) Elytra metallic dark blue to purple (Fig 7A); host cedars. *S. amethystinus* (LeConte)
- Elytra metallic black (Fig 7B); host junipers *S. juniperi* (Fisher)
- 3(1) Mandible with large median tooth on the molar surface (Fig. 4C); labrum short and wide, rectangular (Fig. 4C); elytra with a conspicuous, regular, moderately dense row of semi-erect to erect setae along suture extending from base to very near apex (Fig 4E); outer angle of mandible forming an angle with base near 90°. 4
- Mandible without median tooth (Fig. 4D); labrum long and wide, usually trapezoidal (Fig. 4D); elytra with a sparse row of semi-erect to erect setae along suture usually limited to basal ½ (Fig 4F); outer angle of mandible forming an obtuse angle. . . 5
- 4(3) Elytra relatively short and stout (EL/EW = 1.98–2.18 female, 2.03–2.11 male (95% confidence)); antennae subequal to elytral length in female and >1.4X as long as elytral length in male (TA/EL = 0.97–1.03 female, 95% confidence; 1.48–1.58 male, 95% confidence); male antennomeres 8–11 relatively long and narrow (A8L/A8W = 3.18–3.52; A9L/A9W = 3.57–3.86;

- A10L/A10W = 3.37–3.67; A11L/A11W = 4.67–5.26, all with 95% confidence); pro- and mesotibia expanded and globose-triangular at apex; female pro- and mesotibia apex with dense brush of long silver setae which partially obscures base of tibial spurs (Fig 4G) *S. litigiosus* (Casey)
- Elytra relatively long and narrow (EL/EW = 2.16–2.54 female, 2.17–2.27 male (95% confidence)); antennae shorter than elytral length in female and <1.4X as long as elytra in male (TA/EL = 0.89–0.95 female, 95% confidence; 1.33–1.43 male, 95% confidence); male antennomeres 8–11 relatively short and wide (A8L/A8W = 2.89–3.15; A9L/A9W = 3.17–3.53; A10L/A10W = 2.89–3.27; A11L/A11W = 4.19–4.63, all with 95% confidence); pro- and mesotibia not especially expanded, sometimes somewhat triangular in shape; female pro- and mesotibia apex with brush of yellow setae which does not obscure base of tibial spurs (Fig 4H) *S. terminatus* (Casey)
- 5(3) Scutellum glabrous, or with very few, very minute, punctures that are inconspicuous (Fig. 5A); frons around antennal insertion sparsely punctate (Fig 5A); mandibles large and plate-like, very wide near base (Fig 5B) *S. australis* Giesbert
- Scutellum with obvious punctures, pubescence, or other forms of sculpture (Fig 5C); frons around antennal insertions densely punctate; mandibles not especially wide at base. 6
- 6(5) Femora nearly cylindrical (Fig. 5D), ventrally with pubescence greatly reduced, sparse; disk of elytra with pubescence inconspicuous, fine, sparse, recumbent; antennae and legs uniformly reddish-brown; elytra with a sparse row of semi-erect to erect setae along suture extending from base to apical ¼; dark brown with 2 pairs of pale yellow transversely oval spots (Fig 9B) *S. japonicus* Lacordaire
- Femora short, stout, sinuate, distinctly clavate (Fig. 5E), ventrally with pubescence moderately dense; disk of elytra with pubescence conspicuous, moderately coarse, moderately dense, recumbent, decumbent, and/or semi-erect; antennae and legs ranging in color from unicolor black to orange, to bicolored; elytra with semi-erect to erect setae along suture limited to basal ½; elytra ranging from yellow to orange, with apex black and one pair of median spots (sometimes humeri black as well) or basal 1/3 orange to red and apical 2/3 black (Figs 12, 13) 7
- 7(6) Disk of elytra with 2 distinct colors of pubescence, pale pubescence in pale areas of the elytra and dark pubescence in dark maculate areas of the elytra (Fig 5F); punctures in maculate areas of elytra dense, contrasting with punctures in paler areas which are more widely separate; ground color of elytra usually pale yellow. *S. ligneus* (Fabricius)
- Disk of elytra with only dark pubescence, regardless of the ground color of the elytra (Fig 5G); punctures more or less evenly distributed across elytra; ground color of the elytra usually orange to red. 8
- 8(7) Antennomeres 1–3, as well as the thoracic and abdominal sternites, covered with long, coarse, semi-erect to decumbent pale setae that partially obscures surface (Fig 6A,B); antennomeres proportionally short (Fig 6A); elytral humeri with pale strip of pubescence which often extends posteriorly to about ½ elytra length (Fig 6C); legs and antennae usually black; elytral pubescence very coarse, decumbent to recumbent, obscuring elytra surface somewhat, often surface appearing dusky grey *S. conformis* (Casey)
- Antennomeres 1–3, as well as the thoracic and abdominal sternites, covered with short to long, fine, semi-erect pale setae that does not obscure surface (Fig 6D,E); antennomeres proportionally longer (Fig 6D); elytral humeri often with a few scattered pale setae that are usually limited to basal ¼ (Fig 6F); legs and antennae usually somewhat bicolored; elytral pubescence fine, semi-erect to decumbent, elytral surface not obscured, usually appearing shiny *S. amplus* . . . 9
- 9(8) Elytra with basal 1/3 orange to red and apical 2/3 black (Fig 15A); antennae and legs usually entirely black *S. amplus sequoiae* (Van Dyke)
- Elytra not as above, either orange with black apex and one pair of black median spots, or with base and humeri black and one pair of large median black spots; antennae and legs often bicolored, antennomere 1 usually dark, contrasting with paler antennomeres 2–11; femora usually dark, contrasting with paler tibia and tarsus 10
- 10(9) Elytral base and humeri black; elytral humeri extending posteriorly to about ½ of elytral length making elytra appear long, narrow and convex (Fig 13B). *S. amplus basalis* (Casey)
- Elytral base orange, humeri usually orange; elytral humeri extending posteriorly to only about ¼ length of elytral making elytra appear shorter, wider and flat (Fig 13A). *S. amplus amplus* (Casey)

In the diagnosis for each species, a single slash (/) in the label data represents a line break, and a double slash (//) indicates a new label.

***Semanotus amethystinus* (LeConte, 1853)**

(Figs 4A, 7A, 8, 16A; Map 1)

Physocnemum amethystinum LeConte, 1853: 234

Material examined. 131 males, 159 females.

Holotype. Female (MCZ), examined; labelled “*S. amethystinus*/(Lec.)// Type/3829 [Red label]”.

Diagnosis. This species can be separated from other species of *Semanotus* by the following combination of characters: head, thorax and abdomen black, elytra metallic dark blue to purple; pronotum goblet shaped, broadly round laterally, with basal stalk forming a short pedicel between pronotum and elytra; antennae short, usually ≤1/2 elytra length in both sexes; antennomeres 1, 3–5 long and narrow, >2X as long as wide, especially in male; elytra

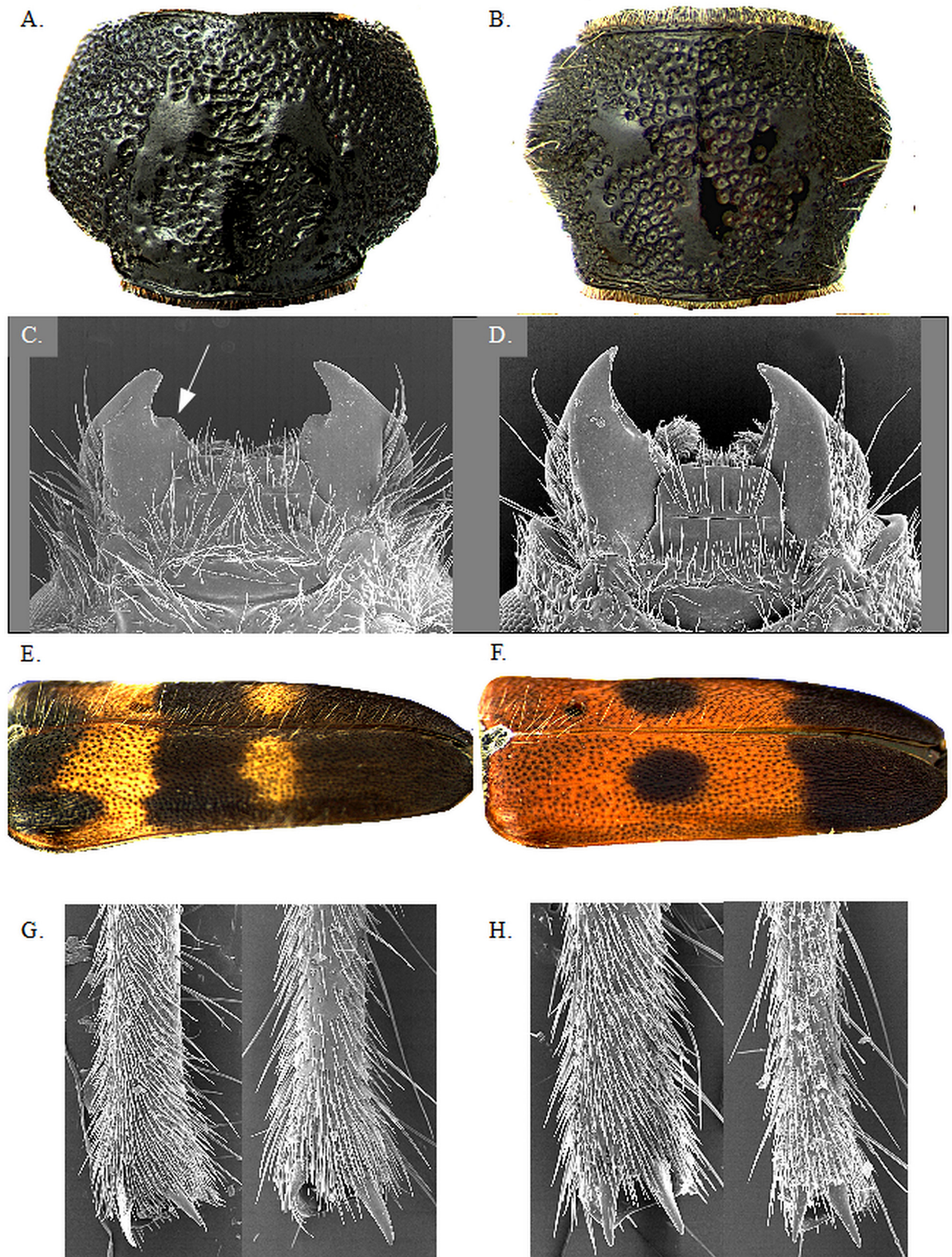

FIGURE 4. A. Pronotum of female *S. amethystinus*, B. Pronotum of female *S. ligneus*, C. Mandibles and labrum of female *S. litigiosus*, D. Mandibles and labrum of female *S. ligneus*, E. Elytral pubescence of female *S. litigiosus*, F. Elytral pubescence of female *S. a. amplus*, G. Pro- and mesotibia of female *S. litigiosus*, H. Pro- and mesotibia of female *S. terminatus*.

minutely punctate, slightly rugulose near base; wing vein r3 very short; wing vein RP very short or obsolete; tibia with long, erect setae (“flying hairs”) greatly reduced in males, absent in females; basal apophysis of abdominal sternum VIII long, longer than the length of one lateral sclerite; basal apophysis of spiculum ventrale short, ~2X length of lateral apophysis; ventral lobe of aedeagus apically sinuate and pointed, dorsal lobe of aedeagus narrowly rounded.

Hosts. *Libocedrus decurrens* Torr. (incense-cedar), *Thuja plicata* Donn (western redcedar).

Flower and Associated Vegetation Records. *Chaemaecyparis lawsoniana* (A. Murr.) Parl. (Port Orford cedar), *Pinus* sp. (pine), *Pseudotsuga menziesii* (Mirb.) Franco (Douglas-fir).

Distribution. Primarily a west coast species, from Washington to southern California, with a few records from high elevation localities in Wyoming, Utah and Colorado.

Remarks. This species seems to get transported around in lumber, as there is a record from Alaska emerging from pine 2x2’s, and a record from New York emerging from cedar wood, however, there is no evidence that suggests that this species is established in these areas.

Semanotus juniperi (Fisher, 1915)

(Fig 7B, 16B; Map 2)

Hylotrupes juniperi Fisher, 1915: 77

Material examined. 37 males, 44 females.

Holotype. Male (USNM), examined; labelled “SantaCatalina Mts/Ariz//Dec. 1/14//Edmonston/WDColr//Juniperus/pachyphloca//12698/Hopk.U.S.//♂//Hylotrupes/juniperi/Fisher/W.S.F.//Type/No.19129/U.S.N.M. [Red label]”.

Diagnosis. This species can be separated from other species of *Semanotus* by the following combination of characters: color black; pronotum broadly round, with basal stalk forming a short pedicel between pronotum and elytra; antennae long, usually >1/2 elytra length in male, ≥1/2 elytral length in female; antennomeres 1, 3–5 short and stout, ~2X as long as wide, especially in male; elytra minutely punctate, moderately rugulose near base; wing vein r3 long; wing vein RP long; tibia with long, erect setae (“flying hairs”) greatly reduced in males, absent in females; basal apophysis of abdominal sternum VIII short, about the length of one lateral sclerite; basal apophysis of spiculum ventrale long, ~2.5X length of lateral apophysis; ventral lobe of aedeagus apically broadly rounded and evenly constricted, dorsal lobe of aedeagus broadly rounded.

Hosts. *Juniperus osteosperma* (= *utahensis*) (Torr.) Little (Utah juniper), *J. deppeana* (= *pachyphloea*) Steud. (alligator juniper).

Flower and Associated Vegetation Records. *Thuja* sp. (cedar).

Distribution. High elevation or arid areas of California, Idaho, Nevada, Colorado, Arizona, New Mexico and Texas.

Remarks. This species is structurally similar to *S. amethystinus*; however, we noted several minor differences in wing venation and genitalia. This species also appears to breed in junipers rather than in cedars.

Semanotus litigiosus (Casey, 1891)

(Figs 4C,E,G, 9A, 10, 16H; Map 3)

Hylotrupes litigiosus Casey, 1891: 25

Material examined. 139 males, 176 females, 53 sex undetermined.

Holotype. Male (USNM), examined; labelled “Cal.//CASEY/bequest/1925//litigiosa Csy [hand written]//TYPE USNM/35920 [Red label]”.

Diagnosis. This species can be separated from other species of *Semanotus* by the following combination of characters: color dark brown to black, rarely with antennomeres 4–11 light brown; elytra ranging from completely dark to having 2 pairs of pale yellow transversely oval spots or wide bands; mandible with large median tooth; elytra with one or multiple rows of dense medium to long, semi-erect to erect, golden setae, extending along suture

from base to very near apex; labrum rectangular, short and wide; fore legs relatively short, femur equal in length to tibia; protibia, especially in males, distinctly triangular in lateral view; pro- and mesotibial apices expanded, somewhat globular, with dense brush of long setae that often obscures tibial spurs, especially in females; elytra short and wide; antennae long, usually as long or longer than length of elytra; apical antennomeres 8–11 long and narrow in males; male genitalia with tegmen apophyses cylindrical and somewhat flattened, basal ring is often broadly joined, emarginate or widely separated.

Hosts. *Abies concolor* (Gord. & Glend.) Lindl. (white fir), *A. grandis* (Dougl.) Lindl. (grand fir), *Pseudotsuga menziesii* (Douglas-fir).

Flower and Associated Vegetation Records. *Pinus* sp. (pine), *Picea* sp. (spruce).

Distribution. Pacific coast, from British Columbia to southern California.

Remarks. The type specimen of this species has been damaged by dermestids (Coleoptera: Dermestidae) and most of the abdomen is missing, however, the specimen is still distinguishable as a male by its antennae and profemora. This species tends to be overall larger, the elytra tend to be shorter and stouter, the antennae longer, and the front and middle tibia of different shape than the following species. This is strictly a western species and is found only west of the Rocky Mountains.

Semanotus terminatus (Casey, 1912), new status

(Figs 4H, 11, 16I,J; Map 4)

Anocomis terminata Casey, 1912: 274

Anocomis canadensis Casey, 1924: 238

Material examined. 356 males, 320 females, 22 sex undetermined.

Holotype. Female (USNM), examined; labelled “Me.//CASEY/bequest/1925//terminata Csy [hand written]//TYPE USNM/35921 [Red label]”.

Diagnosis. This species can be separated from other species of *Semanotus* by the following combination of characters: head, prothorax and abdomen dark brown; antennae light to dark brown, often with antennomere 1 darker; legs ranging in color from reddish-brown to dark brown, sometimes with femora contrastingly darker; elytra light to dark brown, sometimes with faint pale maculation; mandible with acute median tooth; elytra with one or multiple rows of dense medium to long, semi-erect to erect, golden setae, extending along suture from base to very near apex; labrum rectangular, short and wide; protibia narrow, not distinctly enlarged at apex; tibial apices with short sparse setae which do not obscure tibial spurs; elytra long and narrow; antennae short, usually distinctly shorter than elytral length in female; apical antennomeres 8–11 shorter and wider in males; male genitalia with tegmen apophyses cylindrical but slightly inflated apically, bulbous; tegmen basal ring is narrowly joined.

Hosts. *Picea mariana* (Mill.) B.S.P. (black spruce), *Picea glauca* (Moench) Voss (white spruce), *Pseudotsuga menziesii* (Douglas-fir), *Larix* sp. (tamarack).

Flower and Associated Vegetation Records. *Abies concolor* (white fir), *Pinus contorta* Dougl. (lodgepole pine), *P. ponderosae* Laws. (ponderosa pine), *Larix* sp., *Salix* sp.

Distribution. Transcontinental and higher elevation sites, from Alaska to Nova Scotia, south to Colorado.

Remarks. The mandible in the type specimen *A. canadensis* has only a remnant of the median mandibular tooth, with wear marks visible on the molar surface of the mandible.

This species is very similar to *S. litigiosus*, however, the overall habitus is longer and narrower, is often lighter colored and usually smaller in size. The elytral sutural flying hairs in this species tend to be longer, giving the elytra a somewhat pubescent keeled appearance. Eastern forms are relatively easy to separate as they tend to be smaller and more dull brown in color. In the west, this species is often larger than eastern forms, and is confused with teneral or lighter colored specimens of *S. a. basalis* due to the elytra sometimes having lighter banded or spotted areas of color, however the characters in the key should separate the two species.

There is a distinct population of this species in higher elevations of Wyoming and Colorado. The antennae tend to be longer in this population, but the elytra still tends to be longer and narrower and the coloration is more similar to eastern forms. Some specimens also have unusual bi-colored femora.

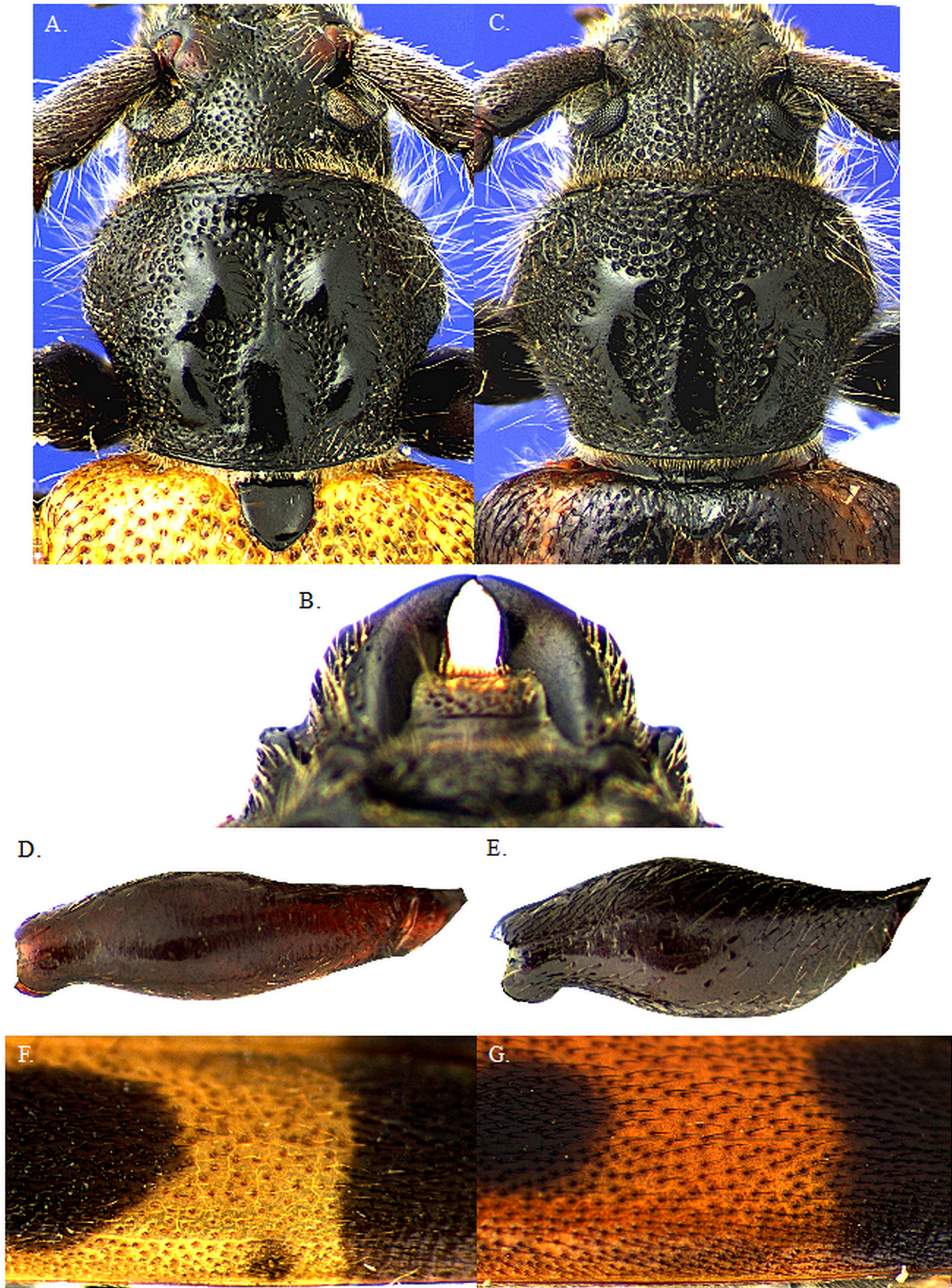

FIGURE 5. A. Pronotum of male *S. australis*, B. Mandibles of male *S. australis*, C. Pronotum of male *S. a. sequoiae*, D. Profemur of male *S. japonicus*, E. Profemur of *S. a. sequoiae*, F. Elytral pubescence of female *S. ligneus*, G. Elytral pubescence of female *S. a. amplus*.

***Semanotus ligneus* (Fabricius, 1787)**

(Figs 4B,D, 5F, 12A, 16C; Map 5)

Callidium ligneum Fabricius, 1787: 153

Callidium rassicum Stephens, 1831: 248, plate XXII fig. 2

Callidium nicolas White, 1855: 321

Anocomis lignea parvicollis Casey, 1912: 272

Material examined. 401 males, 380 females, 121 sex undetermined.

Holotype. Male (ZMUC), examined; labelled “//ZMUC00022367”.

Diagnosis. This species can be separated from other species of *Semanotus* by the following combination of characters: color dark brown to black; elytra pale yellow except for black maculation in the form of one pair of medium sized spots and apical 1/3 of elytra, rarely with spots enlarged basally to form an oblong ‘tongue-like’ longitudinal band; mandible without median tooth; elytral punctation and pubescence distinct: pale setae restricted to pale areas where the punctation is larger and more widely separated, and dark setae restricted to dark areas where the punctation is smaller, and almost contiguous (in the rare case when the basal area of the elytra is dark, the pubescence remains pale), pubescence semi-erect to decumbent; elytra with erect setae along suture usually only in basal 1/2; ventral pubescence white to grey, semi-erect to decumbent, fine, sparse, surface of ventrites not obscured.

Hosts. *Thuja occidentalis* L. (eastern white cedar), *Cupressus* sp., *Juniperus* sp.

Flower and Associated Vegetation Records. *Pinus* sp., *Juniperus* sp.

Distribution. Eastern Canada and USA, south to Oklahoma and eastern Texas.

Remarks. The current definition of *S. ligneus* as treated here is much more limited than the species concept of previous authors, as a number of subspecies have been removed from synonymy and have been given species status. The holotype of *Anocomis lignea parvicollis* is a smaller specimen of *S. ligneus*; it has yellow setae in the pale areas of the elytra and the elytra pale yellow which is typical of *S. ligneus*.

***Semanotus conformis* (Casey, 1912), new status**

(Figs 6A,B,C, 12B, 16D; Map 6)

Anocomis ampla conformis Casey, 1924: 236

Anocomis ampla arizonae Casey, 1924: 236

Material examined. 94 males, 117 females.

Holotype. Female (USNM), examined; labelled “Tom Spalding [half cut off]/IV-11-23/Vineyard. Ut//CASEY/bequest/1925//TYPE USNM/35916 [Red label]/conformis/Casey [Hand written]”.

Diagnosis. This species can be separated from other species of *Semanotus* by the following combination of characters: color dark brown to black, rarely with tibia, tarsi and basal antennomeres lighter, rarely abdomen orange; elytra yellow (rarely) to orange (usually) except for black maculation on the humeri, one pair of median moderate to large black spots and apical 1/3 of elytra; elytral pubescence entirely dark, coarse, decumbent to recumbent, obscuring the surface somewhat making the elytra appear somewhat dusky grey; elytral humeri with patch of long, decumbent white setae which extends along humeri from base to about middle of elytra; overall antennal length short, especially in female; antennomeres 1–3 short, with dense field of contrasting pale colored setae on anterior surface; clypeus deeply impressed and curved or with medially acute posterior margin, which forms a ‘Y’ shape with median frons groove; ventral pubescence white to grey, semi-erect to decumbent, coarse, long, dense, surface of ventrites usually obscured.

Hosts. *Juniperus osteosperma* (= *utahensis*) (Utah juniper), *J. occidentalis* Hook. (western juniper), *Cupressus* sp.

Flower and associated vegetation records. *Juniperus deppeana* (alligator juniper), *J. scopulorum* Sarg. (Rocky Mountain juniper), *Sequoia* sp., *Thuja* sp.

Distribution. Higher elevation and xeric south-western environments of Idaho, Oregon, California, Utah, Arizona, Nevada, Oklahoma, Texas, New Mexico.

Remarks. This species is probably the most difficult of all *Semanotus* to identify as it can be easily confused

with *S. a. basalis*, as they share a similar coloration. The ground color of this species is often duller with a matte finish that may be due to a thicker wax layer on the cuticle to assist with desiccation in hot environments (however, no significant microsculpture was noted). Whereas, most specimens of *S. amplus* tend to have a very shiny, lustrous appearance. The females of this species have notably shorter antennae, which barely reach the middle of the elytra. The ventral pubescence is very dense usually obscuring the sternites. Antennomeres 1–3 have a distinct area of long, white, semi-erect to decumbent setae especially on the dorsal surface, whereas most specimens of *S. amplus* have shorter, white, decumbent setae that encircle the antennomeres. The elytral punctation of *S. conformis* also tends to be less foveate and more widely separated than *S. amplus*.

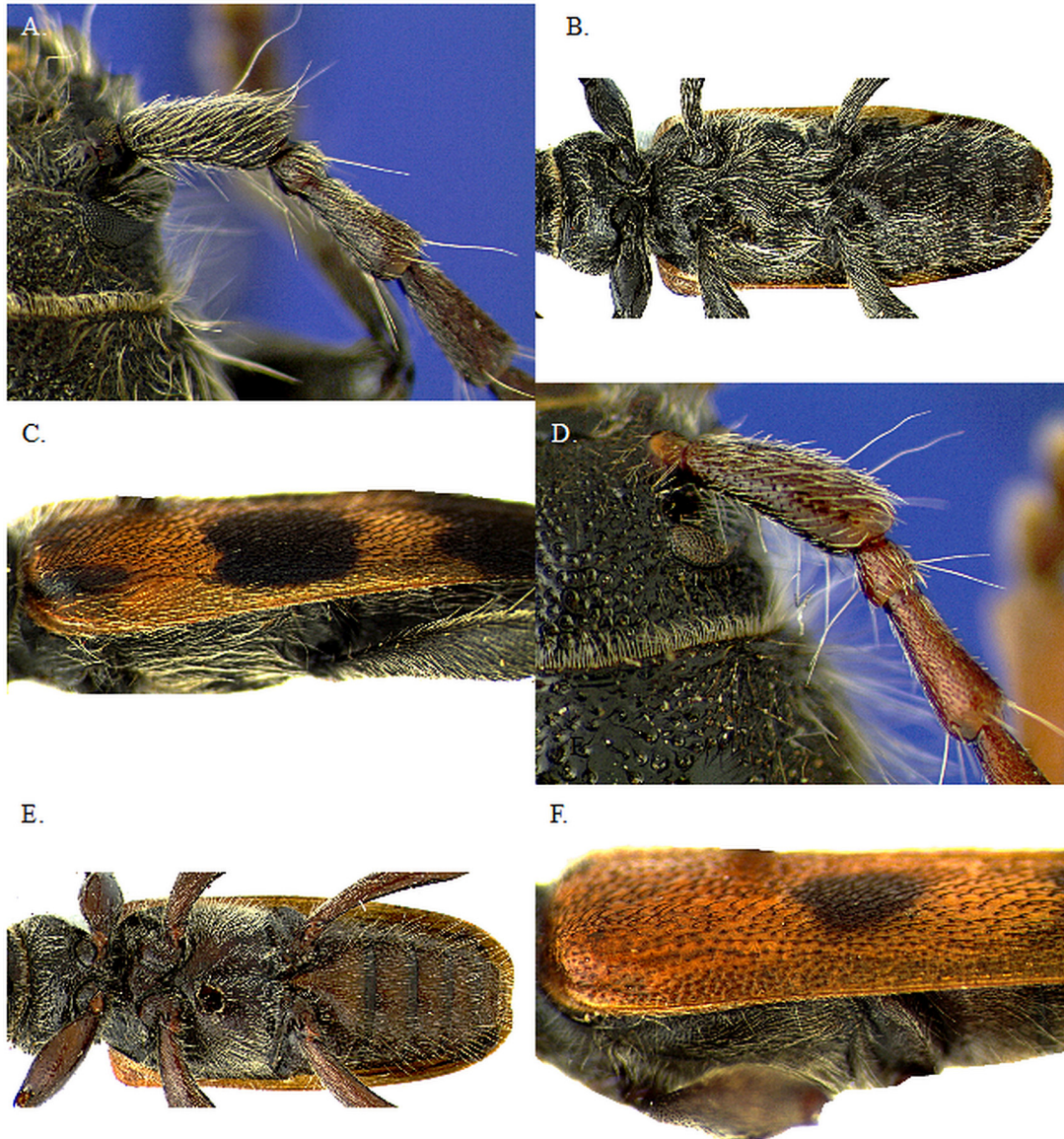

FIGURE 6. A. Basal antennomeres of male *S. conformis*, B. Ventral pubescence of male *S. conformis*, C. Elytral humeri pubescence of male *S. conformis*, D. Basal antennomeres of male *S. a. amplus*, E. Ventral pubescence of male *S. a. amplus*, F. Elytral humeri pubescence of male *S. a. amplus*.

***Semanotus amplus* (Casey, 1912), new status**

Anocomis ampla Casey, 1912: 273

Holotype. Male (USNM), examined; labelled “Cal./CASEY/bequest/1925//TYPE USNM/35913 (Red label)//ampla/Casey [Hand written]”.

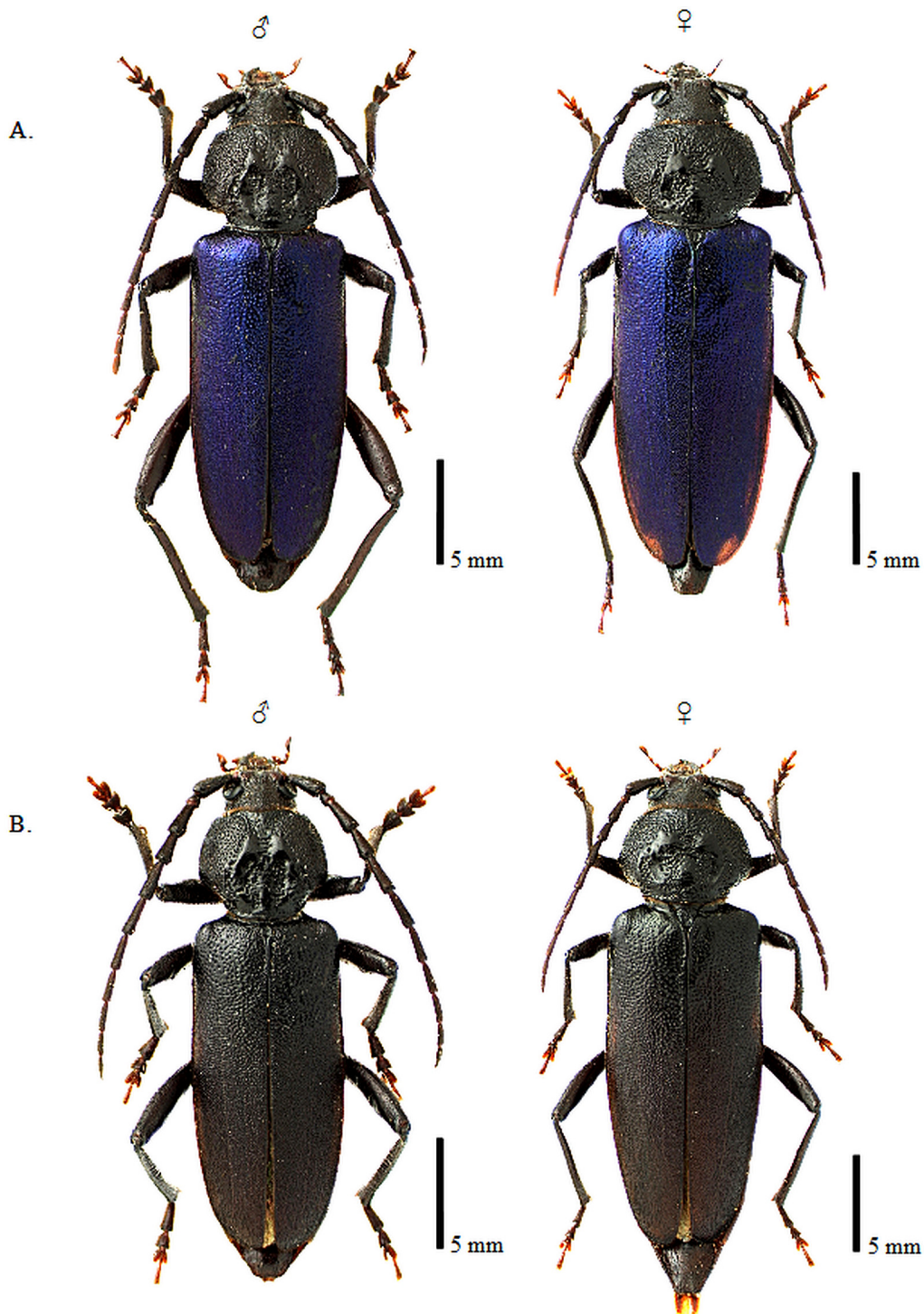

FIGURE 7. Dorsal habitus: A. *S. amethystinus*: California, Northfork ♂; Oregon, Oakridge ♀; B. *S. juniperi*: California, Inyo Co., Westgard Pass ♂; Arizona, Santa Catalina Mountains ♀.

Diagnosis. This species can be separated from other species of *Semanotus* by the following combination of characters: antennae relatively long (♂: usually reaching to at least $\frac{3}{4}$ elytra, often attaining or surpassing apex; ♀: usually reaching to at least mid-elytra), elytra ranging from completely black, completely orange, to various combinations of maculation, as either a median spot and dark apex or with base light and apical $\frac{1}{2}$ dark; pubescence of elytra dark brown to black, decumbent; femoral club strongly globose clavate (♂) to moderately clavate (♀).

Hosts. *Thuja plicata* (western red cedar), *Libocedrus decurrens* (incense-cedar), *Juniperus* sp., *Sequoia*

sempervirens (D. Don) Endl. (redwood).

Flower and Associated Vegetation Records. *Pinus* sp., *Pseudotsuga* sp., *Chaemycparis nootkatensis* (yellow cedar), *Abies* sp.

Distribution. West of the continental divide, from northern British Columbia to southern California.

Remarks. Phenotypically this species is highly variable across its range, and depends partly on host. Specimens reared from *Libocedrus* sp. tend to have a dark orange ground colour. Specimens reared from *Cupressus* sp. or *Sequoia* sp. tend to have a red ground colour. A series reared from *Juniperus occidentalis* near Redmond Oregon are small (<9mm), have yellow elytral ground colour and brown legs and antennae, but retain the dark pubescence typical for *S. amplus*.

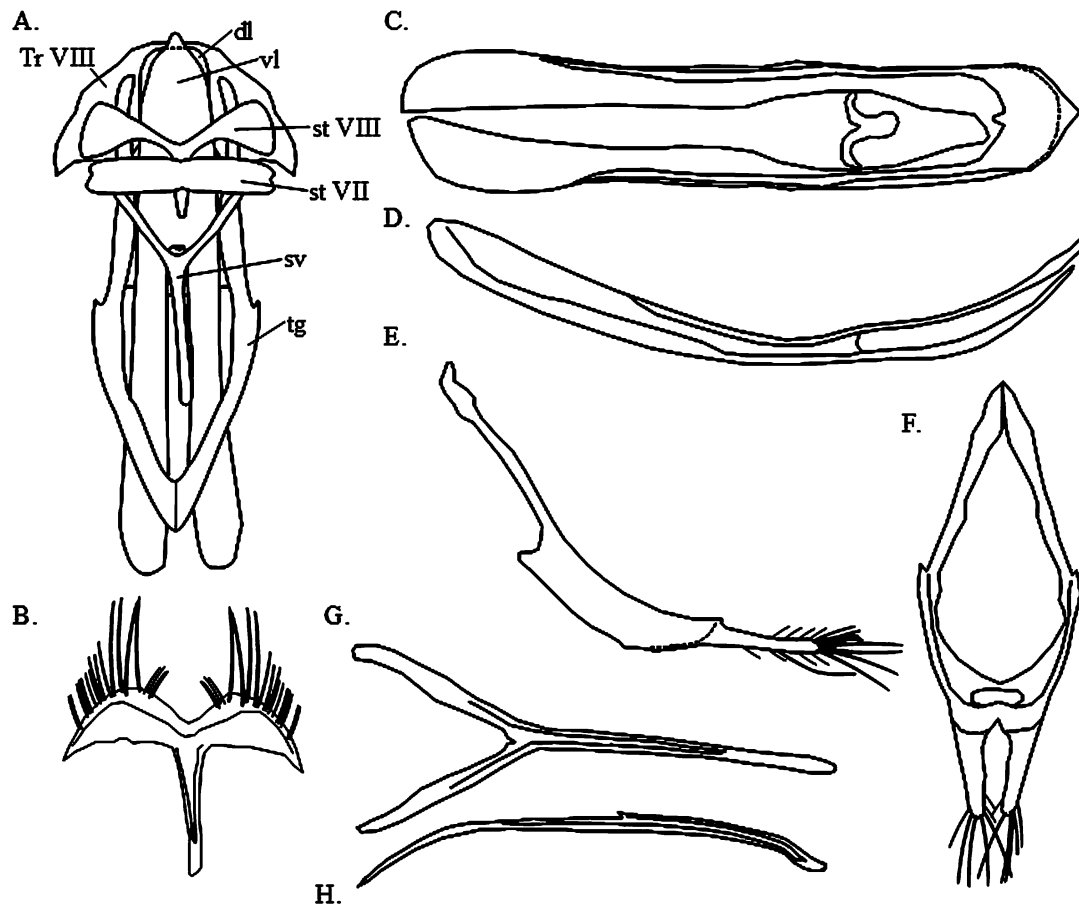

FIGURE 8. Genitalic structures of male *Semanotus amethystinus*. A. General orientation of male genitalia in *Semanotus* sp., ventral view, B. Sternite VIII, C. Median lobe, ventral view, D. Median lobe, lateral view, E. Tegmen, lateral view, F. Tegmen ventral view, G. Spiculum ventrale, ventral view, H. Spiculum ventrale lateral view. Tr=tergite; dl=dorsal lobe; vl=ventral lobe; st=sternite; sv=spiculum ventrale; tg=tegmen.

***Semanotus amplus amplus* (Casey, 1912), new status**

(Figs 5G, 6D,E,F, 13A, 14, 16E; Map 7)

Anocomis ampla angusta Casey, 1912: 273

Anocomis ampla obliviosa Casey, 1924: 237

Anocomis ampla terracensis Casey, 1924: 237

Material examined. 294 males, 253 females, 88 sex undetermined.

Diagnosis. This subspecies can be separated from other subspecies of *S. amplus* by the following combination of characters: head, pronotum, and abdomen dark brown to black; antennal scape light to dark brown, usually

contrasting with remaining antennomeres which are light brown to orange; femur dark brown and contrasting with tibia and tarsomeres which are light brown to orange; elytra light to dark orange, rarely red, with small to medium round to ovoid median black spot, 1/3 of apex black; elytral disk pubescence unicolour black, somewhat decumbent; ventral body and leg pubescence white to grey, moderately dense and long, usually not dense enough to obscure surface; elytral base and humeral angle orange, humeral angle short, usually less than 1/4 of elytra making the elytra appear flat and wide.

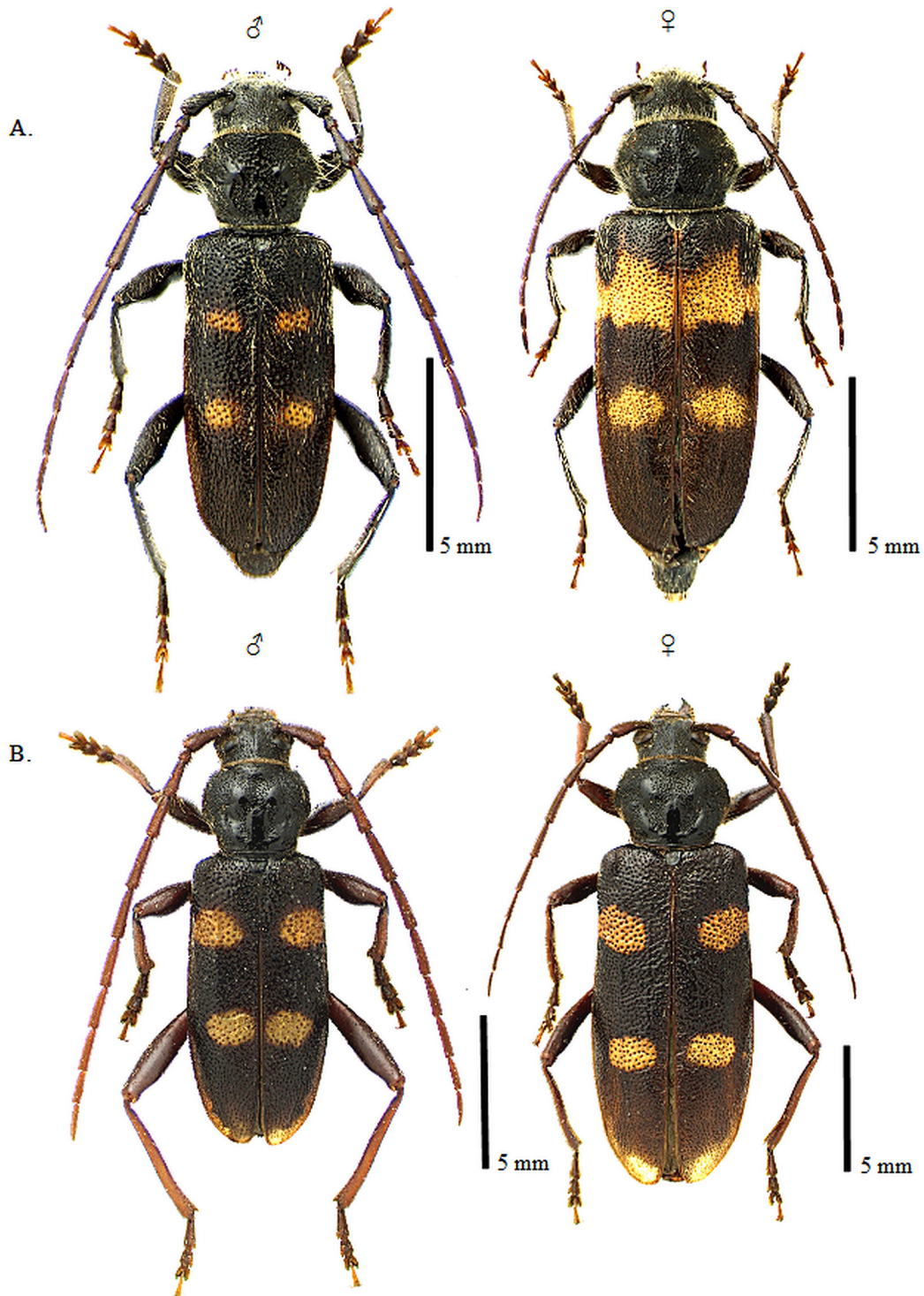

FIGURE 9. Dorsal habitus: A. *S. litigiosus*: California, San Bernardino Co., San Antonio Falls ♂; California, San Bernardino Co., Fallsvale ♀; B. *S. japonicus*: Japan, Tokyo ♂; Japan, unknown ♀.

Hosts. *Libocedrus decurrens* (incense-cedar), *Thuja plicata* (western redcedar), *Juniperus occidentalis* (western juniper), *J. scopulorum* (Rocky Mountain juniper), *Sequoia* sp.

Flower and Associated Vegetation Records. *Pinus* sp., *Chaemycparis nootkatensis* (yellow cedar), *Abies* sp.

Distribution. Southern California north to central British Columbia, Pacific Coast east to continental divide.

Remarks. There seems to be a color cline in this subspecies, with southern populations tending to be lighter orange and northern populations becoming dark orange to almost red. Also, specimens from *Libocedrus* and *Thuja* tend to be dark orange with dark grey highlights, whereas, specimens from *Juniper* tend to be a lighter orange. In California this species may be bivoltine, as there appears to be two distinct adult activity periods, one from March to early May, and another from late August through to mid-September.

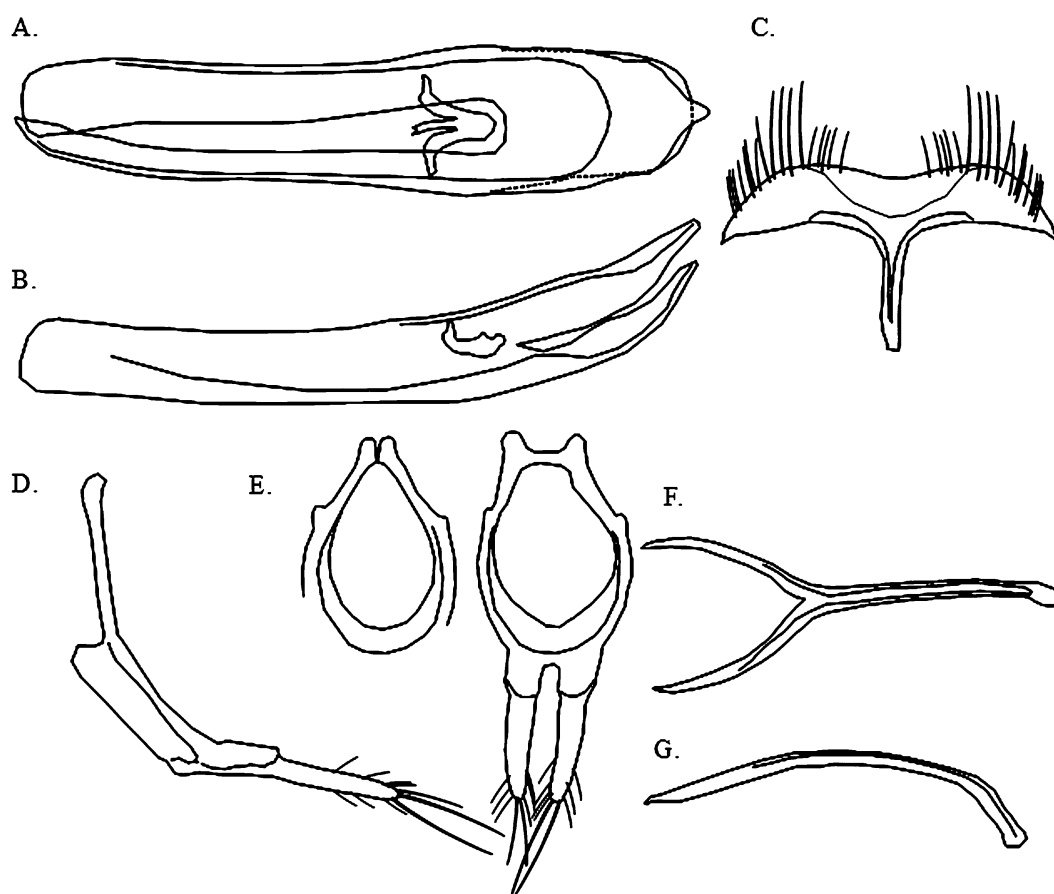

FIGURE 10. Genitalic structures of male *Semanotus litigiosus*. A. Median lobe, ventral view, B. Median lobe, lateral view, C. Sternite VIII, D. Tegmen, lateral view, E. Tegmen, ventral view, F. Spiculum ventrale, ventral view, G. Spiculum ventrale, lateral view.

Semanotus amplus basalis (Casey, 1924), new status

(Figs 13B, 16F; Map 8)

Anocomis basalis Casey, 1924: 237

Semanotus ligneus thujae Van Dyke, 1927: 103

Material examined. 100 males, 111 females, 82 sex undetermined.

Diagnosis. This subspecies can be separated from other subspecies of *S. amplus* by the following combination of characters: elytral base and humeral angles darkened, humeral angle extending further along the length of the elytra (sometimes to near $\frac{1}{2}$) which makes the elytra appear longer and more convex.

Hosts. *Thuja plicata* (western red cedar).

Flower and Associated Vegetation Records. *Pseudotsuga* sp., *Chaemycparis nootkatensis* (yellow cedar),

Sequoia sp., *Abies concolor* (white fir), *Libocedrus decurrens* (incense-cedar).

Distribution. Northern British Columbia to central California.

Remarks. Populations of this subspecies are very similar in appearance to *S. amplus amplus*, and may be just a color variation. This subspecies is often confused with aberrant specimens of *S. terminatus* and *S. conformis*.

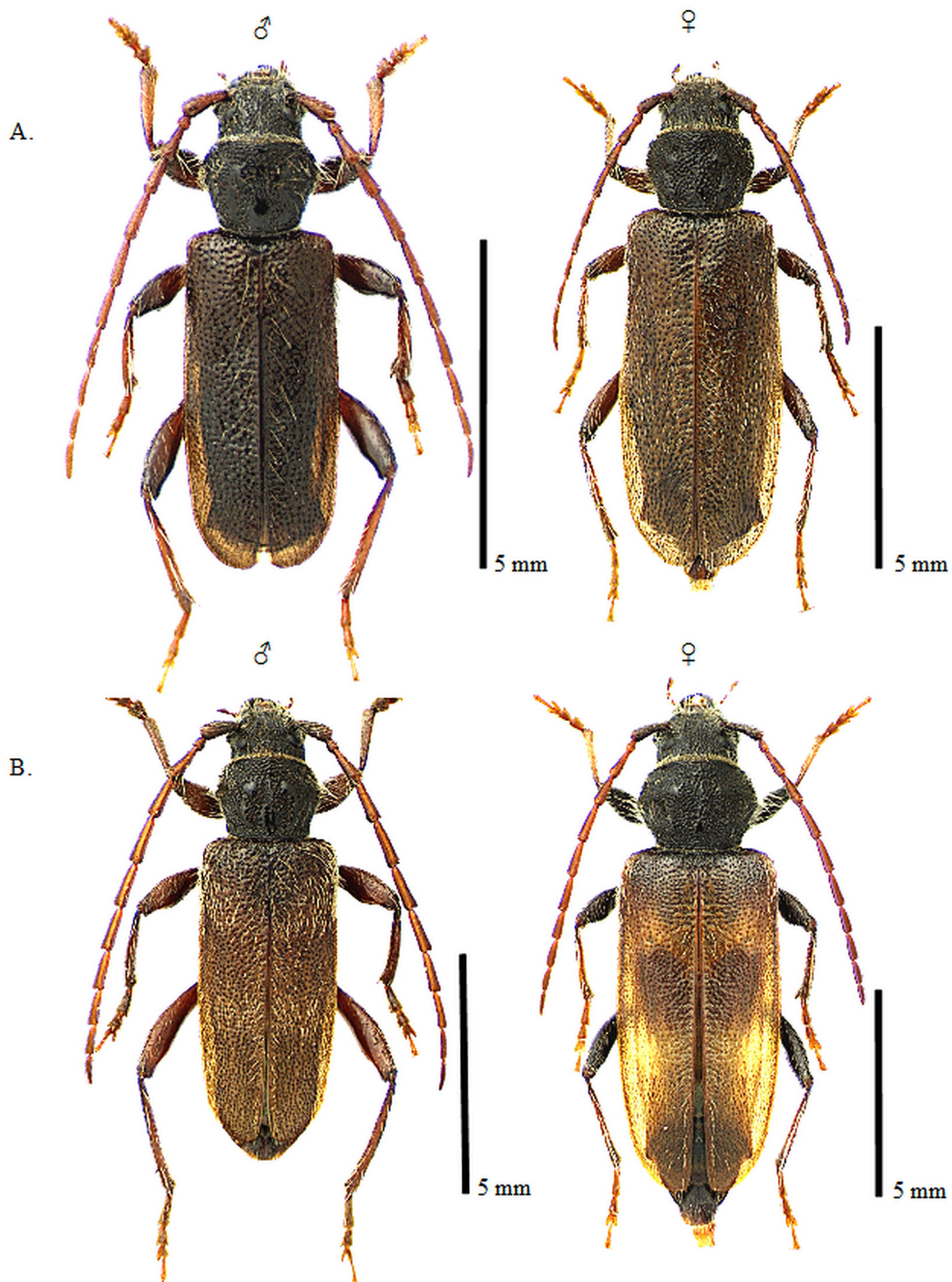

FIGURE 11. Dorsal habitus: A. *S. terminatus*: Quebec, Sainte-Agathe ♂; ♀; B. *S. terminatus*: British Columbia, Creston, ♂; British Columbia, Summerland ♀.

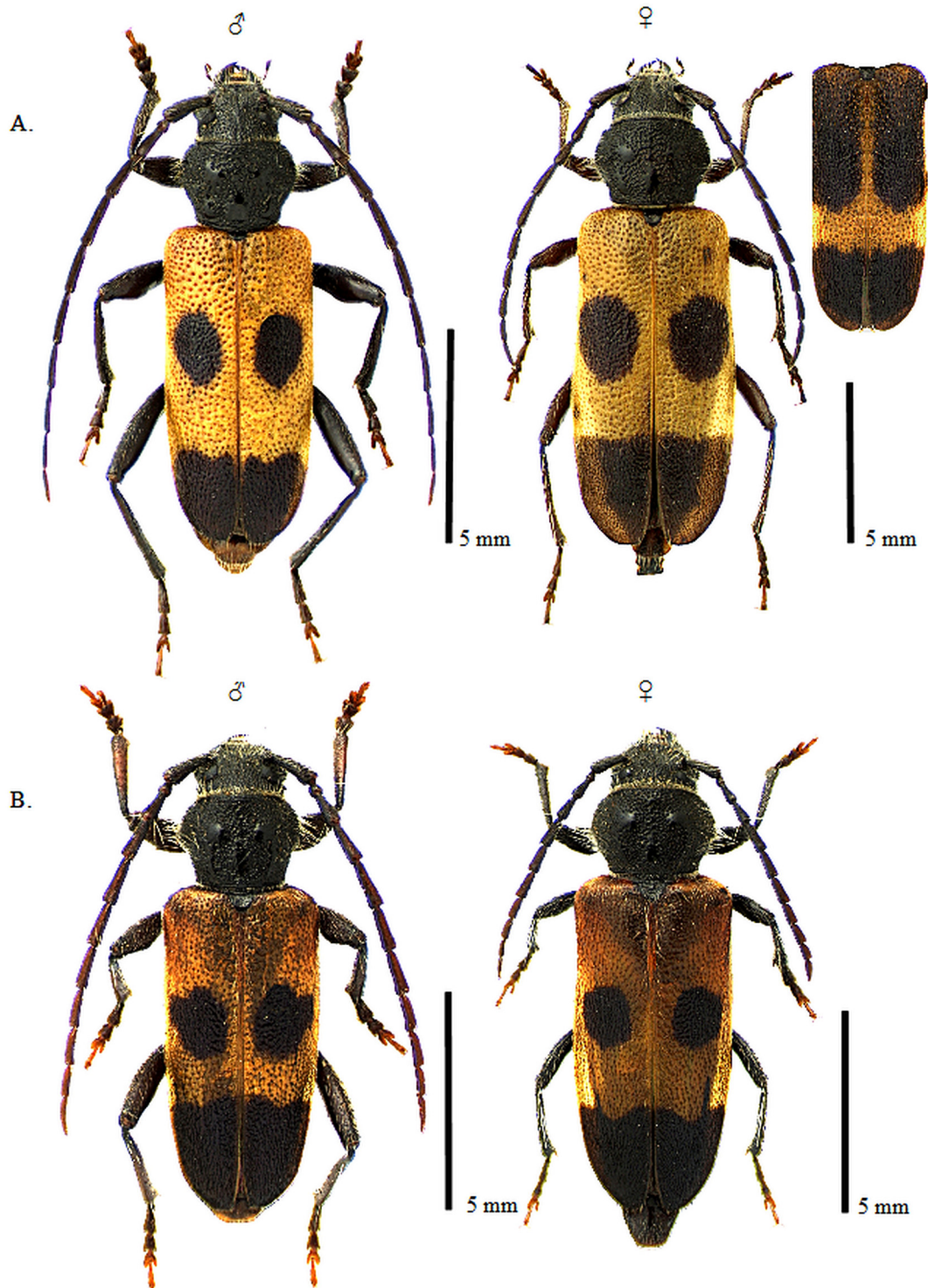

FIGURE 12. Dorsal habitus: A. *S. ligneus*: Quebec, Pont-Rouge ♂; Quebec, Sainte-Famille ♀; showing two color forms: maculate and melanic; B. *S. conformis*: Utah, Saint Georges ♂, ♀.

***Semanotus amplus sequoiae* (Van Dyke, 1923), new status**
(Figs 5C,E, 15A, 16G; Map 9)

Semanotus ligneus sequoiae Van Dyke, 1923

Material examined. 91 males, 118 females.

Diagnosis. This subspecies can be separated from other subspecies of *S. amplus* by the following combination

of characters: elytral disk usually distinctly bicolored with basal 1/3 light brown to red and apical 2/3 dark brown to black; elytral humeral angles usually light brown but occasionally markedly darkened similarly to *S. a. basalis*; antennae are dark brown to black.

Hosts. *Sequoia sempervirens* (redwood).

Flower and Associated Vegetation Records. *Libocedrus decurrens* (incense-cedar).

Distribution. California. One population located near Falls Church, Virginia (see Remarks).

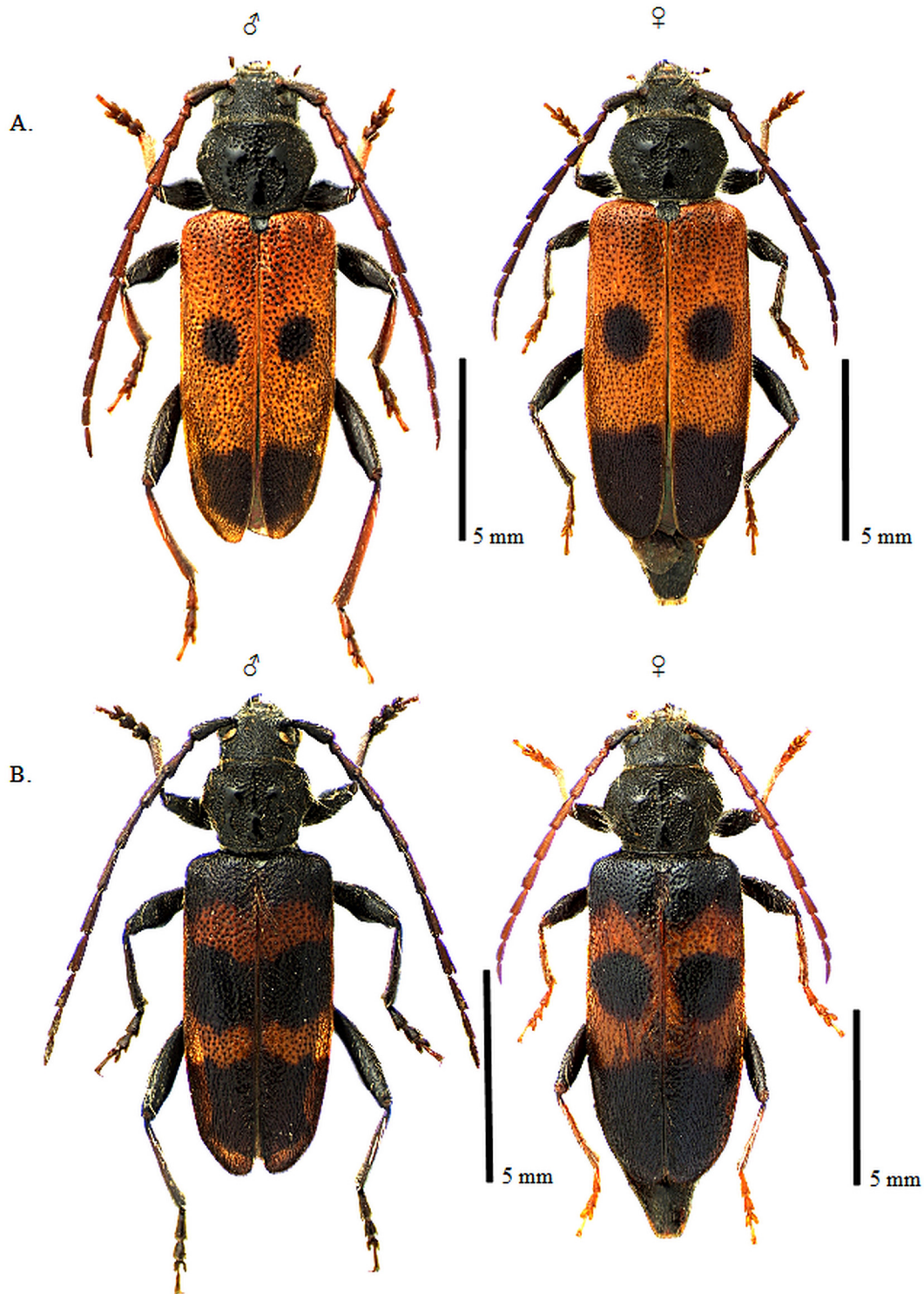

FIGURE 13. Dorsal habitus: A. *S. amplus amplus*: California, San Bernardino Co., Fallsvale ♂,♀; B. *S. amplus basalis*: Oregon, Baker Creek ♂, Washington, Seattle ♀.

Remarks. This subspecies tends to be the most characteristic form among subspecies of *S. amplus*. The coloration is fairly distinctive in that it ranges from completely black to the basal 1/3 of elytra orange to red and the apical 2/3 black. The legs and antennae generally are entirely black, however, there is variation in this character. The punctures in the apical 1/2 of the elytra tend to be closer together than in the basal pale area, with slightly more foveate punctures which gives the surface a somewhat wrinkled appearance.

We examined one series of specimens (9 males, 11 females) reared from *Sequoia sempervirens*, March 24, 1920, from Falls Church Virginia. The specimens all had the same Hopkins Number [Hopk. U.S. 16160a], however, there was no collector information. We presume that these specimens were either collected from a transplanted tree, nursery stock, arboretum, or a log, that originated from the west coast and was shipped to Virginia.

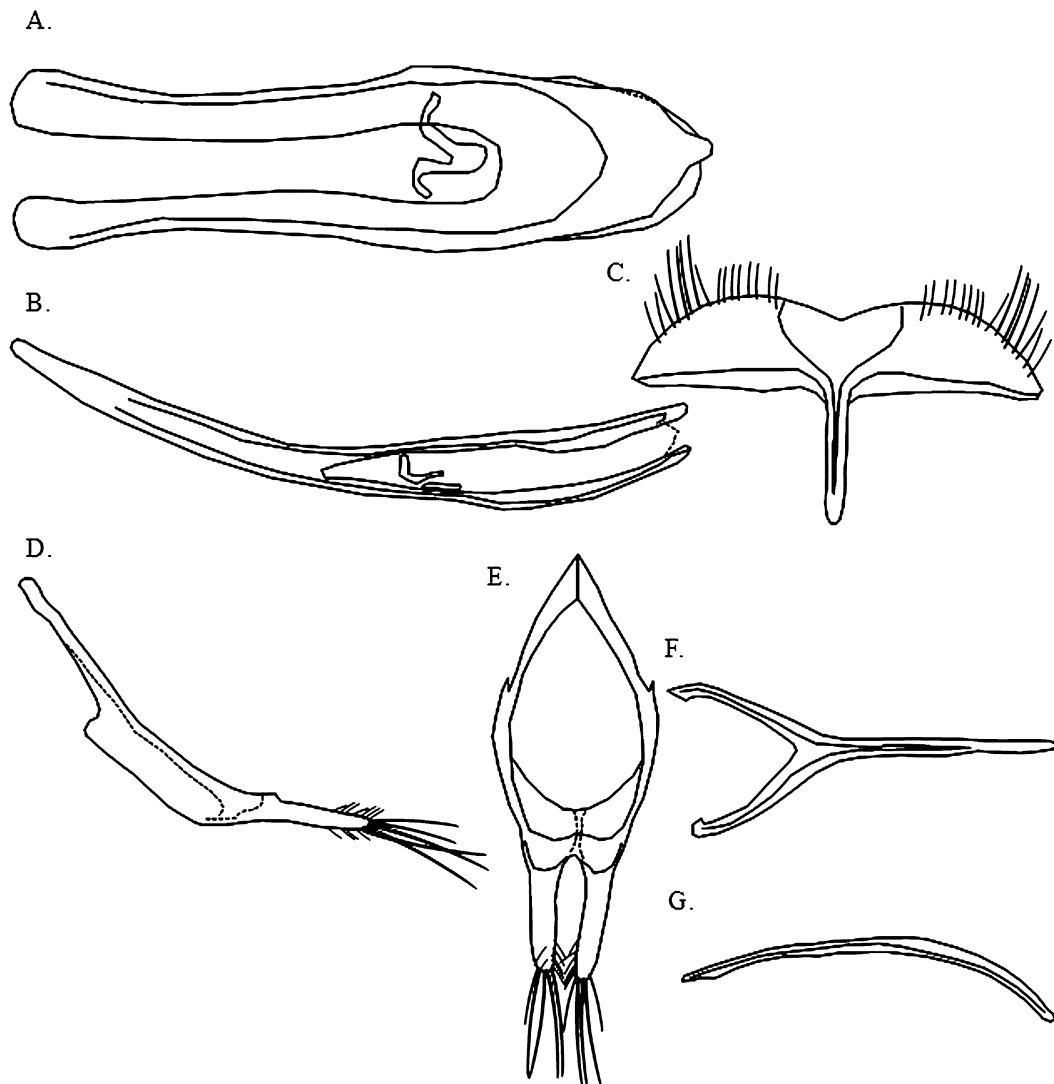

FIGURE 14. Genitalic structures of male *Semanotus amplus amplus*. A. Median lobe, ventral view, B. Median lobe, lateral view, C. Sternite VIII, D. Tegmen, lateral view, E. Tegmen, ventral view, F. Spiculum ventrale, ventral view, G. Spiculum ventrale, lateral view.

***Semanotus australis* Giesbert, 1993**

(Figs 5A,B, 15B)

Semanotus australis Giesbert, 1993: 146

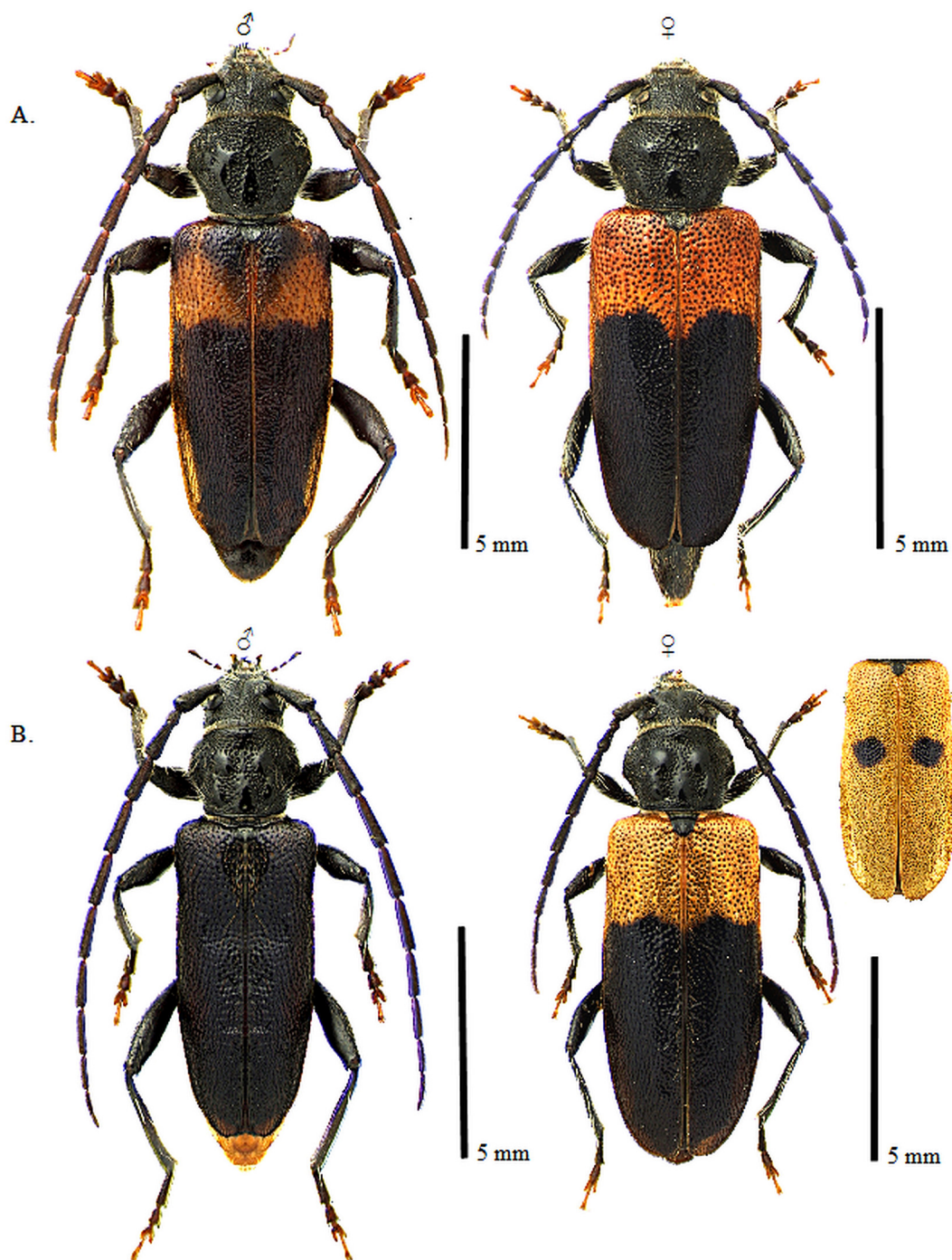

FIGURE 15. Dorsal habitus: A. *S. amplus sequoiae*: California, Healdsburg ♂; California, Santa Cruz Co., Big Basin Redwoods ♀; B. *S. australis*: Guatemala, El Progreso, Los Albores ♂, ♀; showing all three color forms: bicolored, melanic, and maculate.

Material examined. 10 males, 10 females.

Allotype. Female, bicolored form (EMEC), examined; labelled “Guatemala, El Progreso/Los Albores, 5200’/ May 7–8, 1991/E. Giesbert, coll.//ALLOTYPE/SEMANOTUS/AUSTRALIS/GIESBERT [Red label]//U.C. Berkeley/EMEC 69,727”.

Paratypes. Series of 9 males (1 black, 7 bicolored, 1 maculate), 9 females (7 bicolored, 2 maculate) (FSCA), examined; labelled “Guatemala, El Progreso/Los Albores, 5200’/May 7–8, 1991/E. Giesbert, coll.//PARATYPE/ Semanotus/australis Giesbert [Yellow label]”.

Diagnosis. This species can be separated from other species of *Semanotus* by the following combination of

characters: head and prothorax black, abdomen ranging from orange to black; elytra with three distinct color forms: entirely black, basal 1/3 pale yellow to orange and apical 2/3 black, entirely yellow with a single median circular to oval black spot; elytra with a distinct row of erect, medium length setae along suture that extends from base to apical 1/4; mandibles plate-like, wide at base; antennae long, extending past elytral apex, antennomere 4 longer than antennomere 3, especially in males; head with punctures sparse, separated by ~0.5–1X puncture diameter, shallow; antennal insertion very sparsely, shallowly, punctate to impunctate; gena behind eye sparsely punctate and slightly rugose posteriorly; pronotal disk with five large, impunctate callosities; pronotal disk with punctures sparse, separated by 0.5–1.5X diameter, shallow and non-carinate; pronotum with median area of apical margin very sparsely punctate to impunctate; lateral pronotal pubescence of two types: long, sparse, erect, fine hairs, and short, sparse, decumbent fine hairs; scutellum smooth to very sparsely, minutely punctate; elytral punctation non-foveate, surface of elytra appearing smooth and shiny.

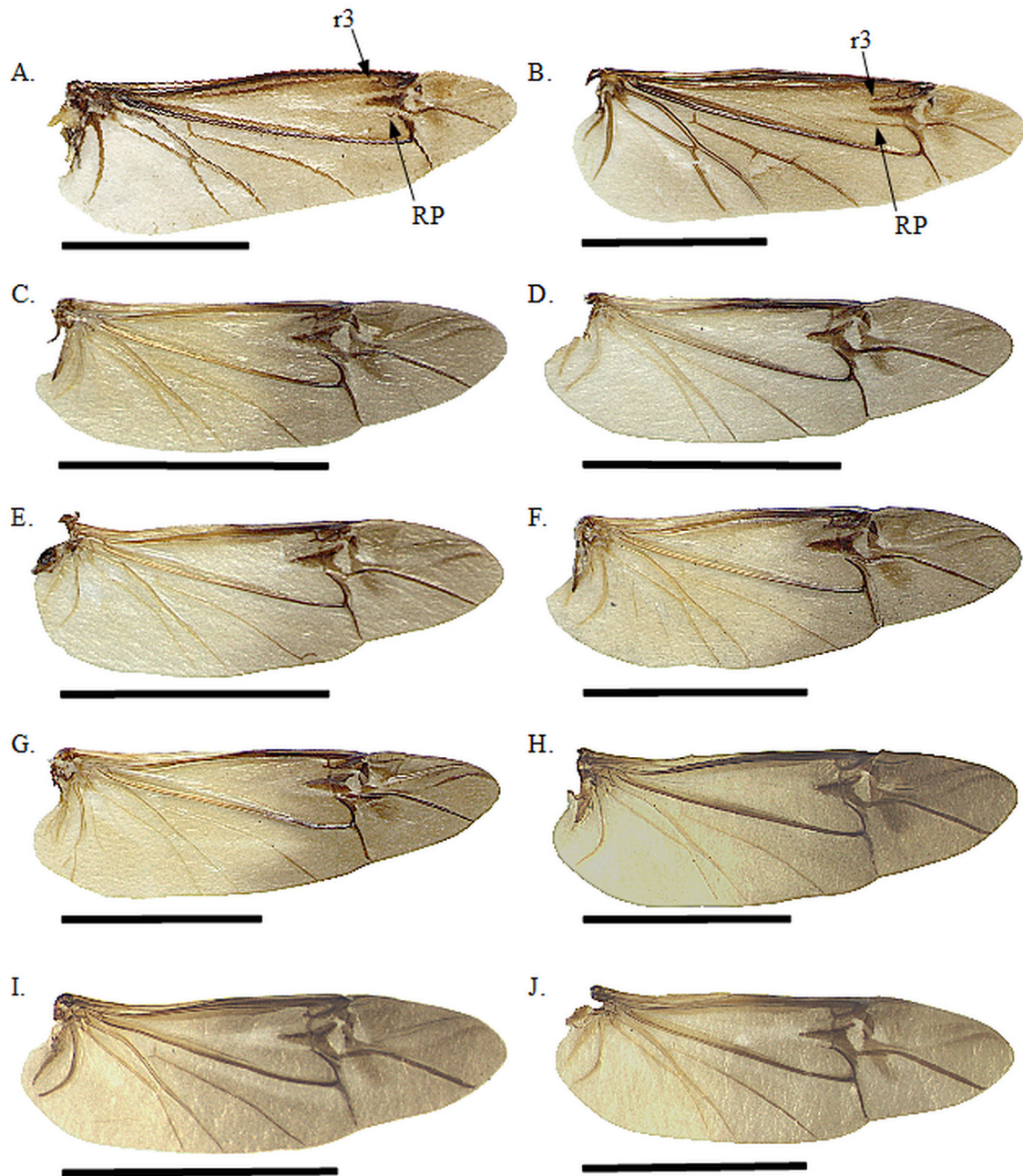
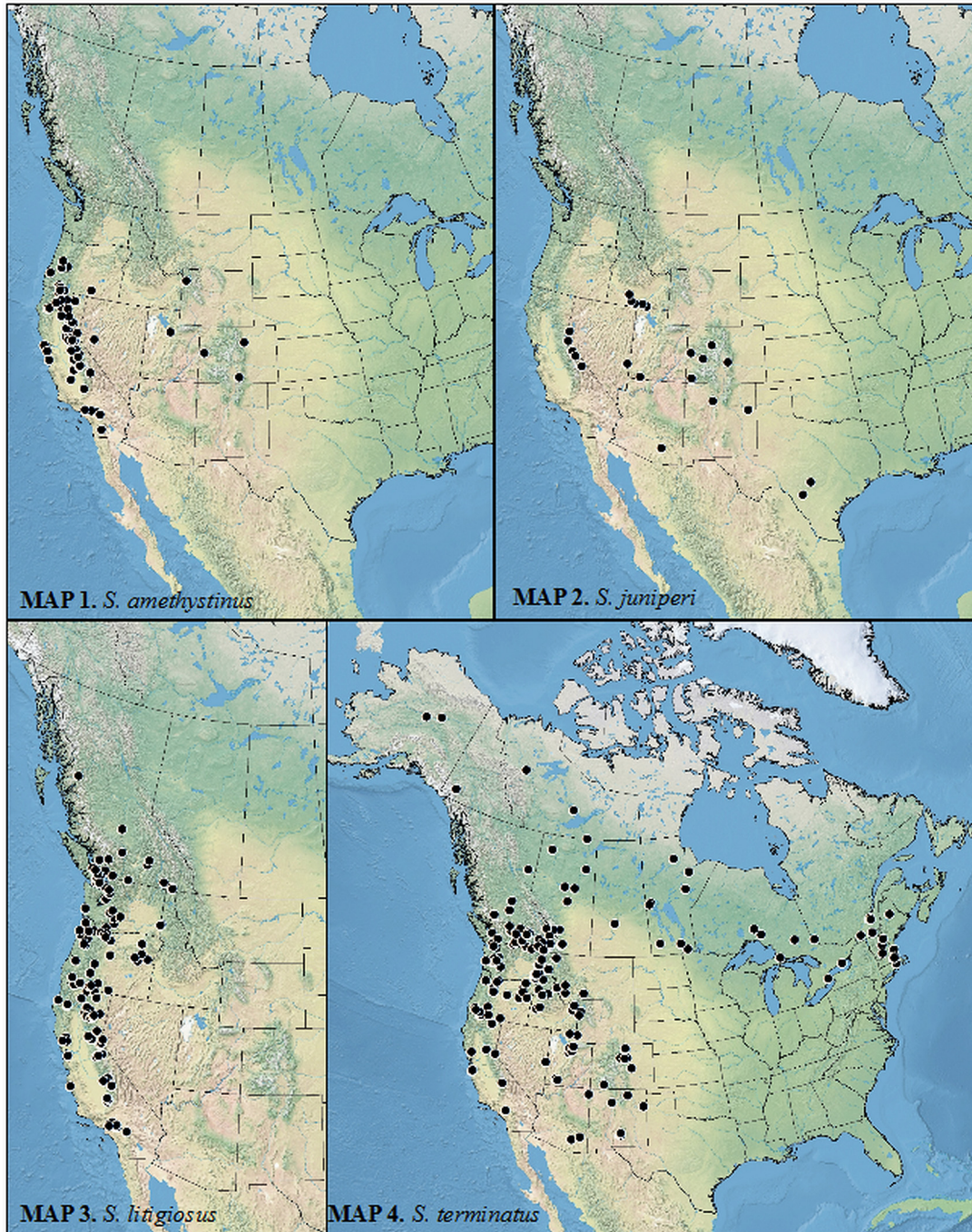

FIGURE 16. Hindwings of North American *Semanotus* species: A. *S. amethystinus*, B. *S. juniperi*, C. *S. ligneus*, D. *S. conformis*, E. *S. amplus amplus*, F. *S. amplus basalis*, G. *S. amplus sequoiae*, H. *S. litigosus*, I. *S. terminatus* (east), J. *S. terminatus* (west). Each scale bar represents 5 mm.



Hosts. "...taken from log of *Cupressus lusitanica* Miller which had been felled the previous year. Based on number of exit holes observed on the log, a large emergence had taken place..." (Giesbert 1993).

Flower and Associated Vegetation Records. *Datura* sp. (Angel's trumpets) (Giesbert 1993), *Phaseolus vulgaris* L. (common bean), label data.

Distribution. South-central Mexico, southeast to Guatemala and Honduras.

Remarks. The allotype of this species is housed at the Essig Museum (EMEC) and not at the California Academy of Sciences (CAS) as was published in Giesbert (1993), and the Florida State Collection of Arthropods (FSAC) has a series of paratypes. The holotype (a male) is listed as being at the CAS, however, this species is not listed in the primary type catalogue database. A male specimen of the melanic form of this species has been intercepted by APHIS in Pharr County, Texas on fruit of *Phaseolus vulgaris* from Honduras (label data, USNM).

Coloration in this species is highly variable, ranging from all black, to bicolored, to maculate with no noticeable differences in morphology.

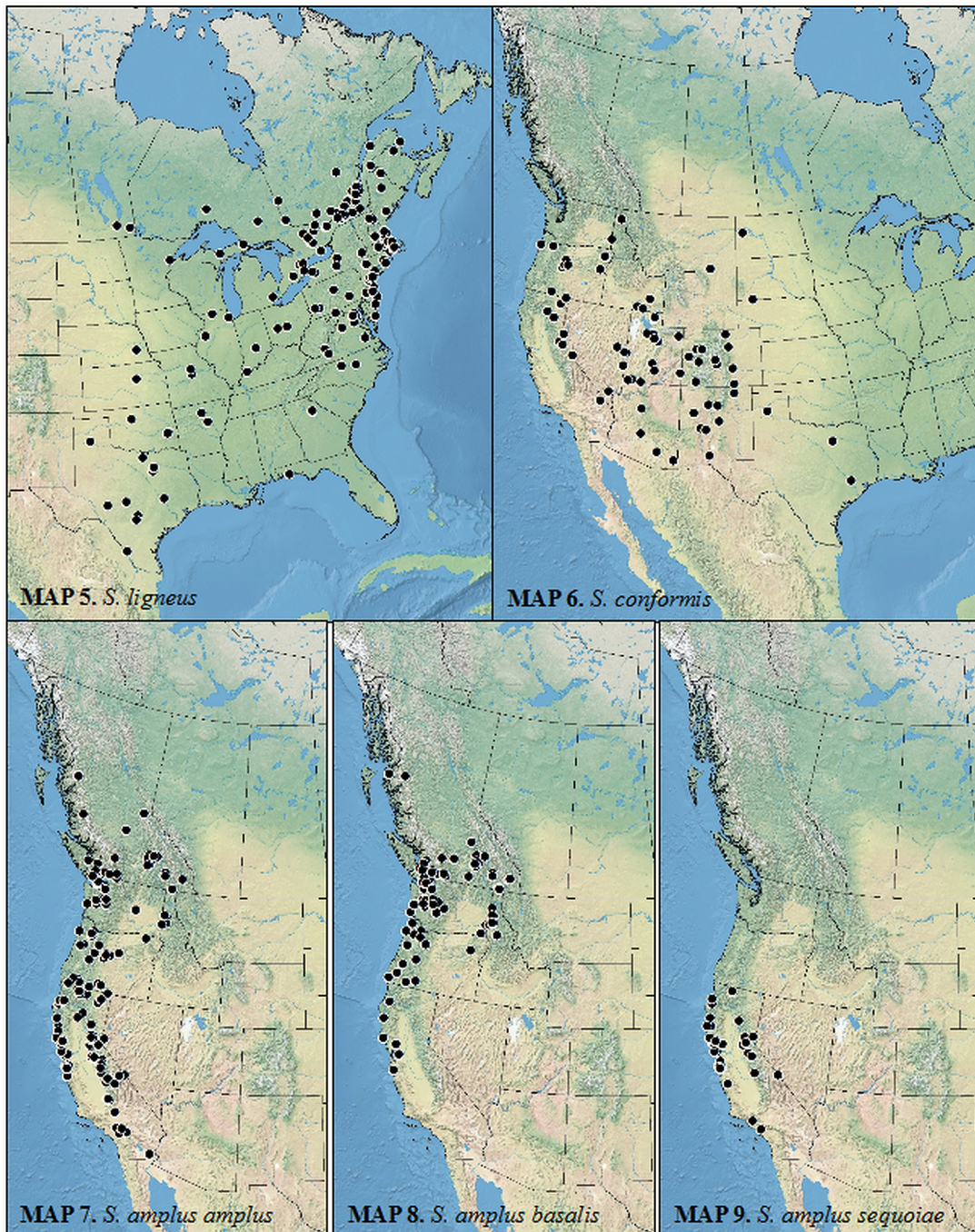

***Semanotus japonicus* (Lacordaire, 1869)**
(Figs 5D, 9B)

Sympiezocera japonicus Lacordaire, 1869: 47

Material examined. 2 males, 1 female.

Holotype. Male (MNMH), examined; labelled “Cordifer Zarnina [hand written in pencil]/Thoms/Cap./MUSEUM PARIS/COLL. J. THOMSON/1952”.

Diagnosis. This species can be separated from other species of *Semanotus* by the following combination of characters: head and prothorax dark brown; antennae, legs and abdomen reddish-brown; elytra dark brown with 2 pairs of transversely oval yellow spots; elytra with an indistinct, sparsely distributed, row of semi-erect, medium length setae along suture, that extends from base to apical ¼; pronotum with 5 large, impunctate calluses, the basal 3 often joined to form a trident-shaped callus; all three femora long, very weakly clavate to almost cylindrical; elytral disk pubescence present but inconspicuous, medium length, very fine, decumbent to recumbent; ventral pubescence semi-erect to decumbent, moderately dense, medium to short in length, not obscuring ventrites; scutellum densely, minutely punctured; mandibles lacking median tooth.

Hosts. *Cryptomeria japonica* (L.F.) D. Don (Japanese cedar), *Chamaecyparis obtusa* (Siebold & Zucc.) Endl. (Japanese cypress) (Ito & Kobayashi 1993).

Flower and associated vegetation records. Unknown.

Distribution. East Asia, Japan, Taiwan, China.

Remarks. This species superficially resembles *S. litigiousus*, however, it lacks the median mandibular tooth, the row of setae along the elytral suture are more sparse and rather indistinct, the legs are much longer and much less clavate, and the appendages and abdomen are much lighter in color, contrasting with the head and prothorax.

A single specimen of this species was intercepted in British Columbia from a wooden box containing mandarin oranges from Japan, and was sent to the United States for identification.

Acknowledgements

The authors would like to thank the following: all the curators and collectors listed for loans of specimens; Serge Laplante and Yves Bousquet for useful advice on the taxonomy and nomenclature of the group; Greg Pohl for editing an early version of the manuscript; the two anonymous reviewers who provided very useful comments; Richard Reardon, USDA Forest Service, Northeastern Area State and Private Forestry for monetary support of the Cerambycidae of Canada and Alaska Project; and our supervisor, David Langor, for never ending support and enthusiasm for all things beetle.

Literature cited

- Apache Software Foundation. Apache Open Office Software. Available from: <http://www.openoffice.org/> (Accessed 7 May 2013)
- Bense, U. (1995) *Longhorn Beetles. Illustrated key to the Cerambycidae and Vesperidae of Europe*. Druckerei Steinmeier, Nordlingen, Germany, 512 pp.
- Casey, T.L. (1891) Coleopterological notices III. *Annals of the New York Academy of Science*, 6, 9–214.
<http://dx.doi.org/10.1111/j.1749-6632.1892.tb55403.x>
- Casey, T.L. (1912) Studies in the Longicornia of North America. *Memoirs on the Coleoptera*, 3, 215–376.
- Casey, T.L. (1924) Additions to the known Coleoptera of North America. *Memoirs on the Coleoptera*, 11, 1–347.
- Craighead, F.C. (1923) North American Cerambycid Larvae: a classification and the biology of North American Cerambycid larvae. *Technical Bulletin, Department of Agriculture, Canada*, 27, 1–239.
- Fabricius, J.C. (1787) Mantissa insectorum sistens eorum species nuper detectas adiectis characteribus genericis, differentiis specificis, emendationibus, observationibus. *Hafniae*, 1, 348 pp.
- Fisher, W.S. (1915) One new genus and two new species of Cerambycidae. *Proceedings of the Entomological Society of Washington*, 17, 77–79.
- Giesbert, E.F. (1993) New species of Cerambycidae (Coleoptera: Cerambycidae) from Guatemala and Chiapas, Mexico. *Coleopterists Bulletin*, 47(2), 137–149.
- Hadley, A. (2010) CombineZP: Image stacking software. Available from: <http://www.hadleyweb.pwp.blueyonder.co.uk/> (Accessed 7 May 2013)
- Hammond, H.E.J. & Williams, D.J. (2011) A revision of the genus *Callimoxys* Kraatz (Coleoptera: Cerambycidae) in America north of Mexico and review of world species. *Coleopterists Bulletin*, 65(3), 246–289.
<http://dx.doi.org/10.1649/072.065.0307>
- Ito, K. & Kobayashi, K. (1993) An outbreak of the *Cryptomeria* bark borer, *Semanotus japonicus* Lacordaire (Coleoptera: Cerambycidae), in a young Japanese cedar (*Cryptomeria japonica* D. Don) plantation. II. Between-tree distribution of adult emergence holes and its relation to tree size. *Japanese Society of Applied Entomology and Zoology*, 28(1), 1–10.

- Kukolova–Peck, J. & Lawrence, J.F. (2004) Relationships among coleopteran suborders and major endoneopteran lineages: Evidence from hindwing characters. *European Journal of Entomology* 101, 95–144.
- Lacordaire, T. (1869) Histoire Naturelle des Insectes. *Genera des coléoptères, vol. 8*, 552 pp.
- LeConte, J.L. (1853) Descriptions of twenty new species of Coleoptera inhabiting the United States. *Proceedings of the Academy of Natural Sciences of Philadelphia*, 6 (1852– 1853), 226–235.
- LeConte, J.L. (1873) New species of North American Coleoptera. Prepared for the Smithsonian Institution. Part II. *Smithsonian Miscellaneous Collections*, 11(265), 279–348.
- Leng, C.W. (1920) *Catalogue of the Coleoptera of America North of Mexico*. Mount Vernon, N.Y., John D. Sherman Jr., 470 pp.
- Linsley, E.G. (1942) A review of the fossil Cerambycidae of North America (Coleoptera). *Proceedings of the New England Zoological Club*, 21, 17–42.
- Linsley, E.G. (1964) The Cerambycidae of North America. Part V. Taxonomy and classification of the subfamily Cerambycinae, tribes Callichromini through Ancylocerini. *University of California Publications in Entomology*, 22, 1–197.
- Linsley, E.G. & Chemsak, J.A. (1997) The Cerambycidae of North America. Part VIII. Bibliography, Index, and Host Plant Index. *University of California Publications in Entomology*, 117, 1–534.
- Lucas, P.H. (1853) Note sur nouveau genre de la famille des longicornes (*Sympiezocera*) qui habite les possessions françaises du nord de l'Afrique. *Revue et magasin de zoologie pure et appliquée* (2)5, 25–30.
- Marseul, S.A. (1856) Diagnoses d'espèces nouvelles qui seront décrites et figurées prochainement Entomol. *Revue et magasin de zoologie pure et appliquée*, (2)8, 47–48.
- Maddison, W.P. & Maddison, D.R. (2011) Mesquite: a modular system for evolutionary analysis. Version 2.75 Available from: <http://mesquiteproject.org> (Accessed 7 May 2013).
- Mermudes, J.R.M. & Napp, D.M. (2004) Comparative morphological study of the Neotropical Cleomenini genera and their transference to the tribes Rhopalophorini Blanchard and Rhinotragini Thomson (Coleoptera, Cerambycidae, Cerambycinae). *Revista Brasileira de Entomologia* 48(2), 251–272. <http://dx.doi.org/10.1590/S0085-56262004000200016>
- Tavakilian, G. & Chevillotte, H. Titan database about Longhorns or Timber– beetles (Cerambycidae). Available from: <http://lully.snv.jussieu.fr/titan/index.html> (Accessed 6 May 2013).
- Monné, M.A. & Giesbert, E.F. (1995) *Checklist of the Cerambycidae and Disteniidae (Coleoptera) of the Western Hemisphere, 2nd ed.* Wolfsgarden Books, Burbank, California, 420 pp.
- Mulsant, E. (1839) *Histoire naturelle des Coléoptères de France, Longicornes*. Maisson, 304 pp.
- Rizzuto, S. (2009) Observations on the larval biology in the genus *Calydon* (Coleoptera: Cerambycidae) with new records in Patagonia, Argentina. *Revista de la Sociedad Entomologica Argentina* 68(3–4), 391–396.
- Sama, G. (2002) *Atlas of the Cerambycidae of Europe and the Mediterranean Area. Volume 1: Northern, Western, Central and Eastern Europe. British Isles and Continental Europe from France (excl. Corsica) to Scandinavia and Urals*. Nakladatelství Kabourek, Zlin, 173 pp.
- Stephens, J.F. (1831) *Illustrations of British Entomology; or, A synopsis of indigenous insects: containing their generic and specific distinctions*. V.8 (Mandibulata 4), 1–366.
- Swofford, D.L. (1998) *PAUP: Phylogenetic analysis using parsimony, V4.0 beta version*. Laboratory of Molecular Systematics, Smithsonian Inst.
- Van Dyke, E.C. (1923) New species of Coleoptera from California. *Bulletin of the Brooklyn Entomological Society*, 1(2), 37–53.
- Van Dyke, E.C. (1927) New species and subspecies of West American Cerambycidae. *Pan–Pacific Entomologist*, 3(3), 99–109.
- Villiers, A. (1978) *Fauna des Coleopteres de France, I. Cerambycidae*. Editions Lechevalier S.A.R.L., Paris, 611 pp.
- White, A. 1855. Catalogue of the coleopterous insects in the collection of the British Museum. *Longicornia*, 2, 8, 175–412.